

# **SOUTH NORTHANTS CRICKET LEAGUE**

**FOUNDED 1920**



## **LEAGUE HANDBOOK AND CLUB DIRECTORY**

**2026 SEASON**

# SOUTH NORTHANTS CRICKET LEAGUE

FOUNDED 1920

(<http://www.sncl.co.uk>)

(<http://snorthantslge.play-cricket.com>)

## **PRESIDENT:**

P.J. Ashby Esq. (2023 - )

## **HON. LIFE VICE-PRESIDENTS:**

B. Spiers Esq. (2013 - )

P.J. Ashby Esq. (2015 - )

D.A. Upstone Esq. (2023 - )

## **VICE-PRESIDENTS:**

B. Hinton Esq.

R. Styles Esq.

## **CHAIRMAN:**

A.P. Jeskins Esq. (2004 - )

# SOUTH NORTHANTS CRICKET LEAGUE

## Management Committee

<b>Chairman &amp; League Welfare Officer</b>	Adam Jeskins (2004) 1, Rowan Close, St. Peter's Park, Brackley, Northants, NN13 6PB. Tel: (07711) 971709 (M) E-Mail: <a href="mailto:adam.jeskins@btinternet.com">adam.jeskins@btinternet.com</a>
<b>Vice Chairman:</b>	Edward Frape (2022) Tel: (01295) 271189 (H)                      Tel: (07595) 223655 (M) E-Mail: <a href="mailto:edwardfrape@yahoo.com">edwardfrape@yahoo.com</a>
<b>General Secretary:</b>	John Fowler (2021) Tel: (01327) 857881 (H)                      Tel: (07860) 301849 (M) E-Mail: <a href="mailto:john.fowler7@btinternet.com">john.fowler7@btinternet.com</a> / <a href="mailto:secretary@snclcricket.co.uk">secretary@snclcricket.co.uk</a>
<b>Treasurer:</b>	Charles Walmsley (2026) Tel: (07879) 440067 (M) E-Mail: <a href="mailto:walmsley302@btinternet.com">walmsley302@btinternet.com</a>
<b>Umpires Secretary:</b>	Charles Walmsley (2021) Tel: (07879) 440067 (M) E-Mail: <a href="mailto:walmsley302@btinternet.com">walmsley302@btinternet.com</a>
<b>Results Secretary:</b>	Alex Beaumont-Dark (2025) Tel: (07508) 196279 E-Mail: <a href="mailto:beaumontdarkalex@yahoo.co.uk">beaumontdarkalex@yahoo.co.uk</a>
<b>Registrations Secretary:</b>	Edward Frape (2022) Tel: (01295) 271189 (H)                      Tel: (07595) 223655 (M) E-Mail: <a href="mailto:edwardfrape@yahoo.com">edwardfrape@yahoo.com</a>
<b>Discipline Co-ordinator:</b>	Tom Smith (2018) Tel: (01295) 660608                      Tel: (07792) 098167 (M) E-Mail: <a href="mailto:liztom@btinternet.com">liztom@btinternet.com</a>
<b>Ground Assessment Co-ordinator:</b>	Adam Jeskins Details As Above
<b>Management Committee:</b>	All Officers as Above  Michael Fisk (2026) Tel: (07742) 026378 E-Mail: <a href="mailto:fisk8@hotmail.co.uk">fisk8@hotmail.co.uk</a>  John Howe (2026) Tel: (07980) 971217 E-Mail: <a href="mailto:john.howe@hotmail.co.uk">john.howe@hotmail.co.uk</a>

**PRESIDENTS:**

1920 / 1932	The Late Lord Teviot (Lt. Col. Charles Kerr D.S.O. - M.C.)
1932 / 1942	The Late Major G.E. Sebag-Montefiore
1946 / 1949	The Late K.L. Lindsay
1949 / 1961	The Late Col. R. Agnew
1961 / 2000	The Late Lord Wardington
2000 / 2009	The Late M.R. Franklin
2009 / 2014	The Late A.H. Turvey
2014 / 2023	The Late D. Laud
2023 /	P.J. Ashby

**CHAIRMEN:**

1920 / 1942	The Late Capt. J.H. Timms
1936 / 1963	The Late F.T. Kielsen
1963 / 1971	The Late C.H. Hill
1971 / 1972	The Late P. Bradley
1972 / 1988	The Late F. Parish
1988 / 2004	The Late D. Laud
2004 /	A.P. Jeskins

**SECRETARIES:**

1920 / 1941	The Late C.H. Chamberlain
1946 / 1984	J.L. Blower
1984 / 1988	J.C. Greenwood
1988 / 1991	The Late I.G. Collett
1991 / 2014	P.J. Ashby
2014 / 2019	C. Reed (2020 Covered by A.P. Jeskins - Covid Season)
2021 /	J. Fowler

---

**ANNUAL GENERAL MEETING**

THIS WILL BE HELD ON FRIDAY 22<sup>ND</sup> JANUARY 2027

AT A VENUE TO BE DECIDED (7.30 PM)

---

# South Northants Cricket League

## Club Directory 2026

### Banbury Lions CC

Ground Address: Hanwell Fields Recreation Ground, Dukes Meadow Drive OX16 1EL  
Ground Tel. No.: 07594 092811

**Secretary:** Ifzal Ahmed  
Tel: Mobile: 07540 005120  
E-Mail: [ifzal517@gmail.com](mailto:ifzal517@gmail.com)

**1<sup>st</sup> XI Captain:** Jignesh Patel  
Tel: 07707 806702 E-Mail:

**2<sup>nd</sup> XI Captain:** Altaf Hussain  
Tel: 07429 461785 E-Mail: [assum2000@yahoo.co.uk](mailto:assum2000@yahoo.co.uk)

---

### Bodicote CC

Ground Address: Kingsfield, White Post Road, Bodicote, Banbury, OX15 4BN.  
Ground Tel. No.:

**Secretary:** Stephen Barlow  
Tel: Mobile: 07725 432016  
E-Mail: [sbarlow519@gmail.com](mailto:sbarlow519@gmail.com)

**1<sup>st</sup> XI Captain:** Luke Symington  
Tel: 07817 315227 E-Mail: [lukesymington96@gmail.com](mailto:lukesymington96@gmail.com)

**2<sup>nd</sup> XI Captain:** Stephen Barlow  
Tel: 07725 432016 E-Mail: [sbarlow519@gmail.com](mailto:sbarlow519@gmail.com)

---

### Castlethorpe CC

Ground Address: Thrupp Close, Castlethorpe, MK19 7PL.  
Ground Tel. No.:

**Secretary:** Nigel Handyside  
Tel: Mobile: 07595 601908  
E-Mail: [nigel.handyside@gmail.com](mailto:nigel.handyside@gmail.com)

**1<sup>st</sup> XI Captain:** Ed Tate  
Tel: 07791 241773 E-Mail: [edward.p.s.tate@gmail.com](mailto:edward.p.s.tate@gmail.com)

---

## Chipping Warden CC

Ground Address: Chipping Warden Cricket Ground, Culworth Road, Chipping Warden, OX17 1LZ  
Ground Tel. No.:

**Secretary:** Clare Brooke  
Tel: Mobile: 07764 579665  
E-Mail: [clarebrooke@btinternet.com](mailto:clarebrooke@btinternet.com)

**1<sup>st</sup> XI Captain:** Daniel Wood  
Tel: 07951 837509 E-Mail: [Reevo07@hotmail.com](mailto:Reevo07@hotmail.com)

---

## Crown CC

Ground Address: Eydon Cricket Club. Eydon Community Sports Field, Eydon, Daventry NN11 3PW  
Ground Tel. No.:

**Secretary:** John Howe  
Tel: 01908 666306 Mobile: 07980 971217  
E-Mail: [john.howe@hotmail.co.uk](mailto:john.howe@hotmail.co.uk)

**1<sup>st</sup> XI Captain:** Paul Fleming  
Tel: 07730 655366 E-Mail: [paul.fleming@t-d-s.com](mailto:paul.fleming@t-d-s.com)

---

## Evenley CC

Ground Address: The Green, Evenley, NN13 5SH.  
Ground Tel. No.:

**Secretary:** Cerys Jones  
Tel: Mobile: 07958 440436  
E-Mail: [cerys71@icloud.com](mailto:cerys71@icloud.com)

**1<sup>st</sup> XI Captain:** George Fox  
Tel: 07703 662415 E-Mail: [georgefox4@hotmail.co.uk](mailto:georgefox4@hotmail.co.uk)

**2<sup>nd</sup> XI Captain:** Tom Benton  
Tel: 07557 372531 E-Mail: [tombenton87@gmail.com](mailto:tombenton87@gmail.com)

---

## Finmere CC

Ground Address: The Playing Fields, Water Stratford Road, Finmere, Bucks, MK18 4AT.  
Ground Tel. No.:

**Secretary:** Debbie Bloomfield  
Tel: Mobile: 07765 874090  
E-Mail: [debbie.bloomfield1@gmail.com](mailto:debbie.bloomfield1@gmail.com)

**1<sup>st</sup> XI Captain:** Nick Wootton  
Tel: 07970 467666 E-Mail: [nwootton@googlemail.com](mailto:nwootton@googlemail.com)

---

## Great Northampton CC

Ground Address: Cold Ashby Playing Field, Stanford Road, Cold Ashby NN6 6EP  
Ground Tel. No.: 07881 237894

**Secretary:** Rosbin Rajan  
Tel: Mobile: 07881 237894  
E-Mail: [rosbinkrajan@gmail.com](mailto:rosbinkrajan@gmail.com)

**1<sup>st</sup> XI Captain:** Vipin Raj Vijaya  
Tel: 07438 512482 E-Mail: [vipinraj725@gmail.com](mailto:vipinraj725@gmail.com)

**2<sup>nd</sup> XI Captain:** Alias Kurian  
Tel: 07404 705958 E-Mail: [aliaskurian45@gmail.com](mailto:aliaskurian45@gmail.com)

---

## Hanslope CC

Ground Address: The Recreation Ground, Castlethorpe Road, Hanslope, Milton Keynes, MK19 7HQ.  
Ground Tel. No.: 07340 129085

**Secretary:** Steve Ritchie  
Tel: 01908 510778 Mobile: 07740 478344  
E-Mail: [s.ritchie1975@sky.com](mailto:s.ritchie1975@sky.com)

**1<sup>st</sup> XI Captain:** John Chilton  
Tel: 07810 579892 E-Mail: [john-chilton@hotmail.com](mailto:john-chilton@hotmail.com)

---

## Heyford CC

Ground Address: Heyford Playing Fields, Middle Street, Nether Heyford NN7 3LL  
Badby Cricket Club, Off Chapel Lane, Badby NN11 3AU  
Ground Tel. No.: 07889 317149

**Secretary:** Mark Fergusson  
Tel: Mobile: 07970 236449  
E-Mail: [mark.fergusson@tritax.co.uk](mailto:mark.fergusson@tritax.co.uk)

**1<sup>st</sup> XI Captain:** Andrew Taylor  
Tel: 07889 317149 E-Mail: [ajheyford@gmail.com](mailto:ajheyford@gmail.com)

---

## Kings Sutton CC

Ground Address: Astrop Road, Kings Sutton, Banbury, Oxon, OX17 3PS.  
Ground Tel. No.: 07415 514403

**Secretary:** Jack Armstrong  
Tel: Mobile: 07756 564249  
E-Mail: [jack.armstrong@live.co.uk](mailto:jack.armstrong@live.co.uk)

**1<sup>st</sup> XI Captain:** Olly Boys  
Tel: 07708 522401 E-Mail: [ollyboys@hotmail.com](mailto:ollyboys@hotmail.com)

---

## Maids Moreton CC

Ground Address: Maids Moreton Playing Fields, Avenue Road, Maids Moreton, MK18 1RJ.  
Ground Tel. No.: 07742 026378

**Secretary:** Matthew Coxhill  
Tel: Mobile: 07954 203529  
E-Mail: [mattcoxhill@gmail.com](mailto:mattcoxhill@gmail.com)

**1<sup>st</sup> XI Captain:** Chris Coxhill  
Tel: 07804 196176 E-Mail: [chriscoxhill@hotmail.com](mailto:chriscoxhill@hotmail.com)

---

## Middleton Cheney CC

Ground Address: The Club House, Queens Street, Culworth OX17 2AT  
Ground Tel. No.: 07775 716204

**Secretary:** Josh Nadin  
Tel: Mobile: [joshuanadin@hotmail.co.uk](mailto:joshuanadin@hotmail.co.uk)  
E-Mail:

**3<sup>rd</sup> XI Captain:** Steve Wilkes  
Tel: 07775 716204 E-Mail: [stevewilkes@talktalk.net](mailto:stevewilkes@talktalk.net)

---

## Preston Bissett CC

Ground Address: Kings Field, The Square, Preston Bissett, Buckingham, MK18 4LP.  
Ground Tel. No.: 07894 466055

**Secretary:** Cynthia Bryant  
Tel: 01280 848321 Mobile: 07884 296168  
E-Mail: [mrsbryant1@outlook.com](mailto:mrsbryant1@outlook.com)

**1<sup>st</sup> XI Captain:** Luke Page  
Tel: 07841 770590 E-Mail: [lukepage49@gmail.com](mailto:lukepage49@gmail.com)

---

## Printers CC

Ground Address: High Street, Great Linford, Milton Keynes MK14 5AX  
Ground Tel. No.:

**Secretary:** Ryan Field  
Tel: Mobile: 07710 649822  
E-Mail: [printerscc1985@gmail.com](mailto:printerscc1985@gmail.com)

**1<sup>st</sup> XI Captain:** Ryan Field  
Tel: 07710 649822 E-Mail: [printerscc1985@gmail.com](mailto:printerscc1985@gmail.com)

---

## Shenley Church End CC

Ground Address: Marsh Drive Pavilion, Great Linford, Milton Keynes MK14 5HH  
Ground Tel. No.: 07980 589074

**Secretary:** Rojin Phillip  
Tel: Mobile: 07799 324081  
E-Mail: [secretary@shenleychurchendcc.co.uk](mailto:secretary@shenleychurchendcc.co.uk)

**1<sup>st</sup> XI Captain:** Aqil Qureshi  
Tel: 07747 046088 E-Mail: [aqilaq2013@gmail.com](mailto:aqilaq2013@gmail.com)

---

## Sibford CC

Ground Address: Sibford School, Sibford Ferris, Banbury, OX15 5QP.  
Ground Tel. No.:

**Secretary:** Edward Frape  
Tel: Mobile: 07595 223655  
E-Mail: [edwardfrape@yahoo.com](mailto:edwardfrape@yahoo.com)

**1<sup>st</sup> XI Captain:** Edward Frape  
Tel: 07595 223655 E-Mail: [edwardfrape@yahoo.com](mailto:edwardfrape@yahoo.com)

---

## Syresham CC

Ground Address: Syresham Sports & Social Club, High Street, Syresham, Brackley, NN13 5HA  
Ground Tel. No.: 01280 423734 / [secretary@syreshamclub.co.uk](mailto:secretary@syreshamclub.co.uk)

**Secretary:** Nic Parry  
Tel: Mobile: 07788 643562  
E-Mail: [nicparry99@googlemail.com](mailto:nicparry99@googlemail.com)

**1<sup>st</sup> XI Captain:** Harry Brock  
Tel: 07702 790319 E-Mail: [harry\\_brock1992@hotmail.com](mailto:harry_brock1992@hotmail.com)

**2<sup>nd</sup> XI Captain:** Scott Wilson  
Tel: 07789 920273 E-Mail: [scott.wilson@avarafoods.co.uk](mailto:scott.wilson@avarafoods.co.uk)

---

## Wardington CC

Ground Address: Wardington Cricket Ground, Corner Mount, Wardington, OX17 1RU  
Ground Tel. No.:

**Secretary:** Anne Wilkins  
Tel: 01295 758167                      Mobile: 07951 794994  
E-Mail: [a.wilkins@hotmail.co.uk](mailto:a.wilkins@hotmail.co.uk)

**1<sup>st</sup> XI Captain:** Thomas Cunniffe  
Tel: 07985 415863                      E-Mail: [tom\\_cunliffe15@hotmail.com](mailto:tom_cunliffe15@hotmail.com)

---

## Wicken Sports CC

Ground Address: Wicken Sports Club, St. John's Lane, Wicken, MK19 6UK  
Ground Tel. No.:

**Secretary:** Piyush Raichura  
Tel:    Mobile: 07747 292 526  
E-Mail: [secretarywsc1849@gmail.com](mailto:secretarywsc1849@gmail.com)

**1<sup>st</sup> XI Captain:** Piyush Raichura  
Tel: 07747 292526                      E-Mail: [secretarywsc1849@gmail.com](mailto:secretarywsc1849@gmail.com)

---

# AMENDMENTS

A series of horizontal dotted lines for writing amendments.

# South Northants Cricket League

## Umpire Directory 2026

### League Panel Umpires (first formed in 1951)

---

Steve Dickinson (2013)	(H) 01280 700598	(M) 07763 405944	(E) <a href="mailto:dicko1951@hotmail.com">dicko1951@hotmail.com</a>
Michael Geelan (2021) <i>(Finmere C.C.)</i>	(H) 01280 848351	(M) 07860 560748	(E) <a href="mailto:michael.geelan54@btinternet.com">michael.geelan54@btinternet.com</a>
John Howe (2024) <i>(Crown C.C.)</i>	(H)	(M) 07980 971217	(E) <a href="mailto:john.howe@hotmail.co.uk">john.howe@hotmail.co.uk</a>
Andrew Howes (2010)	(H) 01327 705115	(M) 07814 076027	(E) <a href="mailto:andrewhowes02@gmail.com">andrewhowes02@gmail.com</a>
Adam Jeskins (2010) <i>(Syresham C.C.)</i>	(H)	(M) 07711 971709	(E) <a href="mailto:adam.jeskins@btinternet.com">adam.jeskins@btinternet.com</a>
Hugh Moran (2015)	(H) 01327 856910	(M) 07596 965286	(E) <a href="mailto:hughlinda@btinternet.com">hughlinda@btinternet.com</a>
Nigel Norman (2023) <i>(Maids Moreton C.C.)</i>	(H) 01280 821594	(M) 07376 103113	(E) <a href="mailto:na.norman@yahoo.com">na.norman@yahoo.com</a>
Tom Smith (2013)	(H) 01295 660608	(M) 07792 098167	(E) <a href="mailto:liztom@btinternet.com">liztom@btinternet.com</a>
Paul Symington (2014) <i>(Bodicote C.C.)</i>	(H)	(M) 07596 253743	(E) <a href="mailto:symington65@aol.com">symington65@aol.com</a>
Charles Walmsley (2012) <i>(Hanslope C.C.)</i>	(H) 01908 511815	(M) 07879 440067	(E) <a href="mailto:walmsley302@btinternet.com">walmsley302@btinternet.com</a>

---

---

---

---



# AMENDMENTS

A series of horizontal dotted lines for writing amendments.

# SOUTH NORTHANTS CRICKET LEAGUE

## FINAL LEAGUE TABLES 2025 SEASON

### LORDS CRICKET BALLS PREMIER DIVISION

Team	P	W	A	T/NR	L	BP	Pen	Pts
<a href="#">Wroxton CC</a>	18	13	0	2	3	30	0	300
<a href="#">Banbury Lions CC</a>	18	13	1	1	3	11	0	291
<a href="#">Thornborough CC</a>	18	10	0	2	6	32	0	252
<a href="#">Evenley CC</a>	18	10	1	1	6	30	5	250
<a href="#">Syresham CC</a>	18	9	0	2	7	49	0	249
<a href="#">Byfield CC</a>	18	8	0	2	8	56	0	236
<a href="#">Sibford CC</a>	18	7	0	2	9	37	0	177
<a href="#">Kings Sutton CC</a>	18	7	0	2	9	31	0	171
<a href="#">Finmere CC</a>	18	2	0	2	14	56	0	96
<a href="#">Woodford Halse CC</a>	18	0	0	2	16	61	0	86

### XLC PRINT STUDIO'S DIVISION ONE

Team	P	W	A	T/NR	L	BP	Pen	Pts
<a href="#">Great Northampton CC</a>	18	17	0	0	1	0	0	345
<a href="#">Castlethorpe CC</a>	18	12	0	0	6	24	0	259
<a href="#">Maids Moreton CC</a>	18	10	0	1	7	27	0	242
<a href="#">Wicken CC, Northants</a>	18	8	0	1	9	43	0	218
<a href="#">Printers CC</a>	18	8	0	1	9	39	0	214
<a href="#">Hanslope CC</a>	18	6	0	2	10	53	0	198
<a href="#">Bodicote CC</a>	18	6	0	1	11	62	0	197
<a href="#">Evenley 'A' CC</a>	18	6	0	1	11	44	0	184
<a href="#">Chipping Warden CC</a>	18	5	0	0	13	64	0	174
<a href="#">Wardington CC</a>	18	2	0	1	15	62	0	107

### DIVISION TWO

Team	P	W	A	T/NR	L	BP	Pen	Pts
<a href="#">Great Northampton CC</a>	18	13	0	1	4	17	0	292
<a href="#">Byfield 'A' CC</a>	18	11	0	1	6	50	0	280
<a href="#">Wroxton 'A' CC</a>	18	12	0	1	5	29	0	279
<a href="#">Thornborough 'A' CC</a>	18	9	0	2	7	38	0	238
<a href="#">Banbury Lions 'A' CC</a>	18	10	0	1	7	29	0	234
<a href="#">Preston Bissett CC</a>	18	9	0	0	9	47	0	227
<a href="#">Crown CC, Bucks</a>	18	7	0	1	10	55	0	210
<a href="#">Woodford Halse 'A' CC</a>	18	5	0	2	11	66	0	186
<a href="#">Brackley CC</a>	18	6	0	1	11	40	0	175
<a href="#">Syresham 'A' CC</a>	18	1	0	0	17	39	0	-31

### CUP WINNERS / RUNNER'S-UP

<b>PREMIER DIVISION</b>	<b>Winner:</b>	Wroxton C.C.	<b>Runner-Up:</b>	Byfield C.C.
<b>DIVISION ONE</b>	<b>Winner:</b>	Great Northampton C.C.	<b>Runner-Up:</b>	Wardington C.C.
<b>DIVISION TWO</b>	<b>Winner:</b>	Great Northampton 'A' C.C.	<b>Runner-Up:</b>	Wroxton 'A' C.C.
<b>WARDINGTON CUP</b>	<b>Winner:</b>	Banbury Lions C.C.	<b>Runner-Up:</b>	Wroxton C.C.

## CONTENTS

### 1. THE SOUTH NORTHANTS CRICKET LEAGUE CHARTER

- 1.1. Title
- 1.2. Objectives
- 1.3. Club Membership
- 1.4. League Administration
- 1.5. Umpires (Law 2) & Scorers (Law 3)
- 1.6. Player Registration
- 1.7. Disciplinary Procedures
- 1.8. Trophies
- 1.9. Safeguarding

### 2. THE LAWS OF CRICKET

### 3. SNCL SATURDAY LEAGUE RULES

- 3.1. The Players
- 3.2. Conduct of Play
- 3.3. The Playing Area (Laws 6, 7, 8, 9, 10 & 41)
- 3.4. Match Duration
- 3.5. Games Affected by Weather
- 3.6. The Result (Law 16)
- 3.7. The League Points System
- 3.8. Promotion & Relegation

### 4. KNOCK-OUT CUP COMPETITION GENERAL RULES

- 4.1. Entry Criteria
- 4.2. Timings
- 4.3. Eligibility of Players
- 4.4. Competition Match Results
- 4.5. Financial Gains
- 4.6. Specific Law Requirements
- 4.7. Over-Rate Penalties
- 4.8. Bowl-Off Regulations

### 5. LEAGUE DIVISIONAL CUP RULES

- 5.1. Entry Criteria
- 5.2. Competition Format
- 5.3. Eligibility of Players
- 5.4. Bowlers' Overs
- 5.5. Timings
- 5.6. Man of the Match

### 6. WARDINGTON CUP COMPETITION RULES

- 6.1. Entry Criteria
- 6.2. Competition Format
- 6.3. Eligibility of Players
- 6.4. Bowlers' Overs
- 6.5. Timings
- 6.6. Man of the Match

7. APPENDIX A - DISCIPLINARY PROCEDURES FOR MEMBER CLUBS
8. APPENDIX B - THE WICKETS (LAW 8)
9. APPENDIX C - THE PITCH (LAW 6), THE BOWLING, POPPING AND RETURN CREASES (LAW 7), THE PROTECTED AREA (LAW 41.11), FIELDING CIRCLE DIMENSIONS (CUP)
10. APPENDIX D - SCHEDULE OF FEES AND FINES
11. APPENDIX E - EXAMPLE TIMINGS FOR LEAGUE MATCHES (NORMAL AND REDUCED)
12. APPENDIX F - *Reserved for Duckworth Lewis Calculation Information*
13. APPENDIX G - TABLE OF BOWLER'S OVERS ALLOWANCES
14. APPENDIX H - ECB REGULATIONS
  - 14.1. ECB Regulations Regarding Young Players in Adult Cricket
  - 14.2. ECB Fast Bowling Match Directives
  - 14.3. ECB Guidance on the Wearing of Helmets
  - 14.4. ECB Fielding Regulations
15. APPENDIX I - CHILD PROTECTION & SAFEGUARDING
16. APPENDIX J - ECB GUIDELINES FOR DISCLOSURE AND BARRING SERVICE (DBS) CHECK REQUIREMENTS
17. APPENDIX K - UMPIRE'S REPORT FORM
18. APPENDIX L - UMPIRE'S GROUND ASSESSMENT & FAIR PLAY FORM (PLAY-CRICKET)
19. APPENDIX M - UMPIRE ASSESSMENT FORM & GUIDANCE NOTES (PLAY-CRICKET)
20. APPENDIX N - DEFINITION OF A FREE HIT
21. APPENDIX O - CALCULATION OF OVER RATE & PENALTY DEDUCTIONS

## 1. THE SOUTH NORTHANTS CRICKET LEAGUE CHARTER

### 1.1. TITLE

- 1.1.1. That the League be called THE SOUTH NORTHANTS CRICKET LEAGUE (“SNCL”)

### 1.2. OBJECTIVES

- 1.2.1. The SNCL is an association of amateur cricket clubs, the members of those Clubs wish to play organised cricket against each other for enjoyment only, there being no profit or business-related motive, other than the awarding of trophies to successful teams and individual players.
- 1.2.2. Through the management of various divisions and competitions to promote all aspects of cricket, maintain and improve ground facilities and develop junior cricket.
- 1.2.3. In addition to do such other things as are incidental or conducive to the attainment of the objectives or are otherwise in the best interest of the SNCL.

### 1.3. CLUB MEMBERSHIP

- 1.3.1. Membership of the SNCL is primarily for those Clubs located within the confines of the South Northamptonshire Council boundaries. Clubs outside the boundaries, however, may apply to join the SNCL at the discretion of the Management Committee.
- 1.3.2. Any Club wishing to apply for membership of the SNCL must do so in writing prior to 30<sup>th</sup> September for entry in the following season.
- 1.3.3. All new Clubs must satisfy the Management Committee in relation to playing standards, ground facilities, youth policy and coaching facilities. There shall be no League or Cup Cricket played on artificial pitches. In addition, all new Clubs must nominate an active Club Secretary, a Club Scorer and if possible, a competent Umpire.
- 1.3.4. The acceptance of new Clubs will be at the discretion of the Management Committee, who shall be empowered to place teams in the division best suited to their abilities. Any amendment to the Constitution of the League will be made in ascending order. With the exception of the 2026 season, there shall be no byes in the Premier Division. The decision of the Management Committee is final.
- 1.3.5. Final decision about membership will be notified by the SNCL to potential new Clubs following the AGM.
- 1.3.6. Membership shall be open to all Clubs irrespective of their individual membership in terms of age, gender, disability, race, ethnic origin, creed, colour, social status and sexual orientation. All bona-fide Clubs shall be deemed to accept the Rules (Constitution) of the SNCL together with the SNCL’s Code of Conduct and observe the ‘Spirit of the Game’.
- 1.3.7. Members Clubs shall play cricket in accordance with the current Laws of Cricket as laid down by the MCC. For the 2026 season, they should be the 2017 Code, 3<sup>rd</sup> Edition - 2022.
- 1.3.8. Should any club resign before fulfilling its matches, all points for and against shall be deleted from the league table and the club shall forfeit all fees. Any Club with two or more teams in the SNCL who wishes to withdraw one of its teams must withdraw the team in the lower or lowest division. This rule only applies 14 days from the start of the season until the completion of the final game.
- 1.3.9. Any Club withdrawing from the SNCL on or after 1<sup>st</sup> March in any season will be fined in accordance with Appendix D.
- 1.3.10. A member club may be expelled from the SNCL for any of the following reasons:
- 1.3.10.1. Bringing the integrity of the SNCL into disrepute.
  - 1.3.10.2. Failure to comply with the SNCL rules.
  - 1.3.10.3. Failure to pay due monies to the SNCL.
  - 1.3.10.4. Showing regular dissent towards Umpires.
- 1.3.11. Immediately any of the above offences in 1.3.10 come to the notice of the Management Committee they should write to the offending Club and fully investigate the matter. On completion of the investigation an Extraordinary General Meeting should be called, and a full report given to the member clubs. The offending club may then take the opportunity to address the member clubs. If at the end of the procedure a member

club or the Management Committee proposes an expulsion, then provided a seconder is forthcoming a vote may be taken as defined in Rule 1.4.6.

- 1.3.12. All players within the SNCL should be registered with the League Registration Secretary, according to the process for registration defined at Rule 1.6.
- 1.3.13. At the discretion of the Management Committee Hon. Life Presidents and Vice-Presidents may be nominated at any time.
- 1.3.14. Entrance Fees (See Appendix D) for the Saturday League and for Cup competitions should be paid at or before the pre-season briefing. After this date League entrance fees will increase by £5 per team. There will also be a rebate for clubs participating in local Junior Leagues on application to the Management Committee.
- 1.3.15. Clubs owing any outstanding debts to the SNCL, e.g., fines, subscriptions etc., for more than one month shall have their fines doubled and given 14 days to pay. Failure to pay the doubled-up amount within 14 days will result in the Club being suspended, fixtures being forfeited, and the Club summoned to appear before the League Management Committee. Failure to pay the outstanding monies within 21 days of suspension will result in the Club being excluded from further participation from the SNCL.
- 1.3.16. All clubs are to provide an email address to the League Secretary for the dissemination of information during the season. It is dependent on the clubs to ensure that this email address is kept up to date during the season as this will be the main point of communication by the SNCL to the club.
- 1.3.17. All Clubs accepted for membership of the SNCL must have registered their Club on the ECB's Play-Cricket System to administer their Club. It is the responsibility of Clubs to ensure there are sufficient numbers or competent persons with Play-Cricket access within their Club to administer the Club and comply with the rules of the League and to notify the League via Play-Cricket of any changes to these persons.
- 1.3.18. Clubs with one team in the SNCL must purchase 2 handbooks per season. Clubs with two teams in the SNCL must purchase a minimum of 3 handbooks per season.
- 1.3.19. All teas for League matches are to be capped at £40.00 per team, totalling £80.00 per match for the home side to supply teas (this is a maximum fee and not an automatic fixed charge).

#### **1.4 SNCL ADMINISTRATION**

- 1.4.1. The SNCL shall be governed by a Management Committee of up to 10 members consisting of the Chairman, Vice Chairman, General Secretary, Treasurer, Umpire's Secretary, Registrations Secretary, Results Secretary, Discipline Officer, League Safeguarding Officer and two further committee members.
- 1.4.2. A quorum shall consist of 4 committee members. The Management Committee shall be empowered to create such sub-committees as it considers appropriate and to co-opt on such members as it deems fit. For the purposes of clarity, the Chairman also has an ordinary vote. The Chairman shall have the casting vote on all Management Committee decisions.
- 1.4.3. The League Secretary shall call an Annual General Meeting ("AGM") for January or February of each year giving at least six weeks' notice in writing.
- 1.4.4. The League Secretary may call an Extraordinary General Meeting ("EGM") in writing at any time at the request of the Chairman, the Management Committee or two thirds of the total number of Clubs within the SNCL.
- 1.4.5. The term of office for each officer of the Management Committee will be for a period from AGM to the following AGM. Officers will be elected at the AGM. Nominations for new officers should be received by the League Secretary not less than three weeks before the date of the AGM. In the event of more than one nomination for any office the result will be decided by a simple majority vote. Existing officers may offer themselves for re-election without nomination.
- 1.4.6. All voting shall be on the basis of one vote per team plus one vote per elected officer on the Management Committee, and by simple majority.
- 1.4.7. At the AGM the following reports will be given by the elected officers:
  - 1.4.7.1. The Chairman's Report.
  - 1.4.7.2. The General Secretary's Report.
  - 1.4.7.3. Statement of Accounts by the Treasurer.
  - 1.4.7.4. Umpire's Secretary's Report.
  - 1.4.7.5. Registration Secretary's Report.

- 1.4.7.6. Results Secretary's Report.
- 1.4.7.7. Safeguarding Officer's Report.
- 1.4.8. Any changes to the rules of the SNCL can only be voted in at a General Meeting (AGM & EGM). Proposals for rule changes, which must be seconded by a club other than the one submitting the proposal, must be submitted in writing to the League Secretary 3 weeks before the General Meeting or 3 weeks after the final game of the season. Proposed rule changes will be circulated 2 weeks before the General Meeting. When a proposed rule change applies to a particular division or group of divisions, only the teams playing in these divisions shall vote on the proposal at the General Meeting. The constitution of divisions presented at the AGM shall define which teams are eligible to vote.
- 1.4.9. The financial arrangements for the following season may be decided at the AGM:
  - 1.4.9.1. Entrance fees (League and Cup games).
  - 1.4.9.2. The rate for all fines.
  - 1.4.9.3. Umpire fees and expenses.
  - 1.4.9.4. Officials Honoraria.
- 1.4.10. A pre-season briefing will be held before the start of the season. The League Secretary shall give 14 days' notice to all the clubs. The purpose of the meeting is to brief all club representatives and secretaries about the administrative arrangements, SNCL Rule changes, and changes to Laws of Cricket for the ensuing season.
- 1.4.11. A fine will be imposed on any club not represented at the AGM, EGM, Ball / Handbook Collection evening or the pre-season briefing, in accordance with Appendix D.
- 1.4.12. Any Club who has outstanding debts to the SNCL at the close of business of the pre-season meeting, shall have the equivalent amount of pounds (£) outstanding, deducted in points.

## **1.5. UMPIRES (LAW 2) & SCORERS (LAW 3)**

- 1.5.1. Each club within the SNCL shall endeavour to provide a competent umpire to the SNCL's pool of umpires. Where possible neutral umpires will be appointed to all games.
- 1.5.2. Where a Club provides an Umpire to the League Umpire's Panel, that Club shall not be penalised for failing to provide a non-playing Umpire for a home match, as long as their League Umpire is officiating at another game for the League on the same day.
- 1.5.3. Each Club playing in the current season in the Premier Division, MUST provide one competent non-playing Umpire to officiate their HOME matches. Failure to provide a non-playing Umpire will result in a 5-point penalty deduction. An Umpire under this Rule shall be empowered as an SNCL Panel Umpire and shall be entitled to receive fees and expenses as Rule 1.5.9.
- 1.5.4. Where an SNCL Panel Umpire is appointed in the Premier Division or Division 1, the Home Club non-playing Umpire will stand as a Colleague.
- 1.5.5. The SNCL encourage all Clubs in the Premier Division and Division 1 to provide a non-playing Umpire to each match whether Home or Away, and in the event of both Clubs providing an Umpire, they shall stand together as Colleagues with the exception of Rule 1.5.4 above.
- 1.5.6. The SNCL encourage all Clubs below Division 1 to provide a non-playing Umpire to each match whether Home or Away, and in the event of both Clubs providing an Umpire, they shall stand together as Colleagues. An Umpire standing under this rule is not entitled to claim SNCL Umpires' expenses but must be accepted and respected in the same way as an SNCL Panel Umpire by both teams.
- 1.5.7. Where a player-umpire is used in conjunction with a Home Club Umpire, the Player shall not stand at the Bowler's end.
- 1.5.8. Umpires should conform to the current Laws of Cricket as laid down by the MCC, including being appropriately dressed.
- 1.5.9. Umpires will receive a fee payment and travelling costs for each game they officiate at. Umpires' fees will be as laid out in Appendix D. Umpires travelling expenses of 45p per mile may be claimed for their return journey by the shortest route from their home to the match ground if such expense has been incurred by them. Minimum expenses will be £5. In addition, a free tea may be claimed.
- 1.5.10. It is the responsibility of the home club to fully pay the umpire, his fees and travelling costs, prior to commencement of the 2<sup>nd</sup> innings and then reclaim half those costs from the visiting team. If no play takes

place and an umpire has travelled to the ground, he may claim travelling expenses. Umpire fees, however, are not payable in such cases. Should a match be cancelled, and the home Club has not informed the Umpire, the Umpire will be entitled to the full fee and travelling expenses.

- 1.5.11. All umpires to report any irregularities or misconduct to the Umpires Administration Secretary using the official report form (See Appendix J).
- 1.5.12. An umpire unable to officiate at a match allocated to him should notify the Umpires Appointments Secretary as soon as possible before the match date, to enable the Umpires Appointments Secretary to appoint a substitute if possible.
- 1.5.13. Only SNCL appointed Umpires and Non-Playing Umpires (Premier Division & Division 1) can award penalty runs under Law 41 and apply Law 42 in respect of Player's Conduct.
- 1.5.14. All penalties for all Laws are to be applied in all matches.
- 1.5.15. All SNCL appointed Umpires and Non-Playing Umpires (Premier Division & Division 1) shall send a Ground Assessment Card after each match (within 3 days), irrespective of play or not, assuming they attended (See Appendix K).
- 1.5.16. The SNCL will endeavour to provide and pay for course fees for those Umpires who are either part of the SNCL Panel, or as Home Club Umpires. In addition, the SNCL will provide a current copy of the MCC Laws of Cricket to all Panel Umpires and Clubs in the Premier Division and Division 1.

## **1.6. PLAYER REGISTRATION**

- 1.6.1. All players must be registered with the SNCL through the ECB Play-Cricket portal by the Club who wishes their registration. Players will then be registered in perpetuity with that club until the Club withdraws that Players registration on Play-Cricket.
- 1.6.2. All players must be registered with the League prior to the match in which they intend to play. Player Registration can be submitted for approval up until 08.00 hours (for a Saturday match) or 12.00 hours (for a midweek match).
- 1.6.3. Any player wishing to transfer from a club to another shall request the Club he wishes to transfer to, to complete the transfer process on Play-Cricket. Should the club for which the player is registered object to the transfer, it must state its objections in writing to the League Secretary within 5 days of the receipt of the Transfer request. No transfer of a registered player will be allowed after the 12th Saturday of the playing season.
- 1.6.4. On completion of the Play-Cricket Transfer process, a remittance of £5 must be in sent to the League Treasurer (either by cash, cheque or BACS). No transfer will be deemed to have taken place until the fee has been paid and the player transfer approved on Play-Cricket.
- 1.6.5. Any club being found guilty of having played an ineligible player may be subjected to a fine (in accordance with Appendix D) at the discretion of the Management Committee. All points for that game will be forfeited and a win awarded to the opponents.

## **1.7. DISCIPLINARY PROCEDURES**

- 1.7.1. The responsibility lies with the captains for ensuring that play is conducted within the spirit and traditions of the game as well as within the Laws of Cricket and the SNCL rules.
- 1.7.2. Whenever possible any incident or complaint should be resolved by the captains, assisted by the umpire, unless a serious offence takes place.
- 1.7.3. A serious offence is defined as follows:
  - 1.7.3.1. Any violence or threat of violence intended or otherwise, to any umpire, player, other official or a member of the spectators.
  - 1.7.3.2. Any act that may be described as against Rule 1.3.6.
  - 1.7.3.3. Any dissent to an umpire involving foul or abusive language.
  - 1.7.3.4. Any club found guilty of having played an ineligible player.
  - 1.7.3.5. Any other behaviour which would bring the game or the SNCL into disrepute.
- 1.7.4. If an Umpire or Club proposes to make a complaint about a Club or Player they should inform the Umpires Secretary in writing within 48 hours of the incident, using the Official Report Form (See Appendix J).

- 1.7.5. On receiving an official complaint, the Management Committee will, within 48 hours of receiving a written complaint, forward on to the SNCL Disciplinary Panel for action (refer to Appendix A - SNCL Code of Conduct).

## **1.8. TROPHIES**

- 1.8.1. Clubs winning trophies and individuals winning “man of the match” trophies must have their club’s name and/or individual name and winning year engraved on such at their expense.
- 1.8.2. Clubs and individuals receiving trophies must sign a Trophy Bond. Clubs and individuals are held responsible for any loss or damage incurred to any Trophy whilst in their possession.
- 1.8.3. All Divisional Trophies must be returned to the Management Committee by 31<sup>st</sup> July. All Cup Trophies must be returned to the Management Committee by 30<sup>th</sup> June. All trophies must be returned in a clean undamaged state and duly engraved. Clubs or individuals failing to return trophies by this date will be fined in accordance with Appendix D.

## **1.9. SAFEGUARDING**

- 1.9.1. The SNCL as an ECB affiliated League, adopts the ECB ‘Safe Hands’ policies and procedures around Safeguarding.
- 1.9.2. The SNCL Committee will include an appointed League Safeguarding Officer who shall be qualified and registered with the ECB and hold a current and valid Disclosure and Barring Service (DBS) check carried out through the ECB.
- 1.9.3. The SNCL Safeguarding Officer shall maintain a record of all safeguarding officers for each Member Club.
- 1.9.4. All Clubs must have a trained and appointed Safeguarding Officer (valid from the 2022 season) registered with the ECB through their respective County Cricket Board, with a current and valid Disclosure and Barring Service (DBS) check carried out through the ECB. All Clubs are to provide the name, contact details and qualification dates to the League on the Club Details Form each season.

## 2. THE LAWS OF CRICKET

### 2.1. Preamble:

- 2.1.1 All games of cricket within the SNCL will be played in accordance with the M.C.C. Laws of Cricket and specific rules laid down by the SNCL.

### 2.2 The Spirit of Cricket:

- 2.2.1. "Cricket is a game that owes much of its unique appeal to the fact that it should be played not only within its laws but also within the Spirit of the Game. Any action which is seen to abuse this spirit causes injury to the game itself. The major responsibility of ensuring the spirit of fair play rests with the captains."
- 2.2.2. The captains are responsible at all times for ensuring that play is conducted within the Spirit of the Game as well as within the Laws.
- 2.2.3 In the event of a player failing to comply with instructions by an umpire, or criticising by word or action the decisions of an umpire, or showing dissent, or generally behaving in a manner which might bring the game into disrepute, the umpire concerned shall in the first place report the matter to the other umpire and to the player's captain and instruct the latter to take action. If an umpire or club proposes to make a complaint to the SNCL about a club or player, they should comply with Rule 1.5.11.
- 2.2.4. According to the Laws the umpires are the sole judges of fair and unfair play. As such the umpires may intervene at any time and it is the responsibility of the captains to take action where required. (Refer to Law 3.7)
- 2.2.5. The umpires are authorised to intervene in cases of:
- 2.2.5.1 Time wasting (Refer to Law 41.9 & 41.10).
  - 2.2.5.2 Damaging the pitch (Refer to Law 41.11, 41.12, 41.13, 41.14, 41.15).
  - 2.2.5.3 Dangerous or unfair bowling (Refer to Law 41.6, 41.7 & 41.8).
  - 2.2.5.4 Tampering with the ball (Refer to Law 41.3).
  - 2.2.5.5 Any other action that they consider to be unfair (Refer to Law 41.19 and Law 42 Player's Conduct).
- 2.2.6. The Spirit of the Game involves RESPECT for:
- 2.2.6.1 Your opponents.
  - 2.2.6.2 Your own captain and team.
  - 2.2.6.3 The role of the umpires.
  - 2.2.6.4 The game's traditional values.
- 2.2.7 It is against the Spirit of the Game:
- 2.2.7.1 To dispute an umpire's decision by word, action or gesture.
  - 2.2.7.2 To direct abusive language towards an opponent or umpire.
  - 2.2.7.3 To indulge in cheating or any sharp practice, for instance:
    - to appeal knowing that the batsman is not out.
    - to advance towards an umpire in an aggressive manner when appealing.
    - to seek to distract an opponent either verbally or by harassment with persistent clapping or unnecessary noise under the guise of enthusiasm and motivation of one's own side.
- 2.2.8 There is no place for any act of violence on the field of play. See Rule 1.7.3.1.
- 2.2.9 Captains and umpires together set the tone for the conduct of a cricket match. Every player is expected to make an important contribution to this.

### **3. SNCL SATURDAY LEAGUE RULES**

#### **3.1. THE PLAYERS**

- 3.1.1. All players will be registered as defined in Player Registration in Rule 1.6.
- 3.1.2. Where a club enters two teams in the League all players registered will be qualified to play in the First Team, but Rule 3.1.3 will apply to the 'A' Team.
- 3.1.3. An 'A' Team may only field a maximum of three players who have played five league matches or more each with the First Team during the current season.
- 3.1.4. Each captain or deputy shall nominate the players using the official ECB card to one of the umpires but in the absence of umpires to the opposing captain, before the toss. No player may be changed after the nomination without the consent of the opposing captain (Refer to Law 1, 24 & 25).
- 3.1.5. In the interest of safety, any player under 18 years of age, playing in a senior game, shall not be allowed to bat or field on the square without wearing a helmet (See ECB Directives - Appendix G).
- 3.1.6. In the lowest League Division, teams may additionally field players registered to another South Northants Cricket League Club; however fielding players older than the Under 16 age group from other Club will render a Club ineligible for promotion from the lower Division. Age groups are based on the age of a player at midnight on 31<sup>st</sup> August in the year preceding the current season (See ECB age group directives - refer to Appendix G).

#### **3.2. CONDUCT OF PLAY**

- 3.2.1. The starting time for all matches will be 1.30pm.
- 3.2.2. All League matches shall start with a new ball purchased through the SNCL purchase scheme, the home team is responsible for providing the spare ball / balls. (No. of spare balls required depends on the boundary hinterland but a minimum of six balls to be provided of varying condition). The balls shall be shown to the umpire (or opposition captain where no umpire appointed) before the game and left ready for use.
- 3.2.3. In all Divisions, each team will supply one match ball i.e. each innings will start with a new ball.
- 3.2.4. The match ball and the spare ball / balls are to be given to the umpire 20 minutes before the start of the match.
- 3.2.5. No composite balls are to be used.
- 3.2.6. Umpires will report clubs who do not supply the correct ball and a fine will be imposed for each offence of up to £20.
- 3.2.7. The Captain or Deputy to toss-up at least 15 minutes before the match starting time, but not earlier than 30 minutes before the match starting time (Refer to Law 13.4).
- 3.2.8. Clubs must fulfil their first team fixtures at all times and field their strongest possible side.

#### **3.3. THE PLAYING AREA (LAWS 6, 7, 8, 9, 10, 19 & 41)**

- 3.3.1. The playing area is to be marked out in accordance with the Laws of Cricket - refer to Appendix C The Pitch (Law 6, The Bowling, Popping and Return Creases (Law 7) and the Protected Area (Law 41.11).
- 3.3.2. The boundary line is to be marked completely in white or rope with white or yellow plastic boundary markers (Refer to Law 19.2).
- 3.3.3. All infringements regarding the marking out of the playing area should be reported to the Umpires Secretary and to the League Ground Assessment Officer. Any such infringement could result in a fine and a deduction in points being imposed.
- 3.3.4. If a club has the facility to cover its pitch (Law 6) and bowler's run-ups (Law 10), it must be used when players are forced to leave the field of play through rain.

#### **3.4. MATCH DURATION (SEE APPENDIX E)**

- 3.4.1. All League matches shall be limited to 40 overs per side.
- 3.4.2. If the batting side is unable to commence a match at the specified time, they will be penalised one over for every 3.5 minutes of delay. If the fielding side is unable to commence a match at the specified time, they will be penalised five (5) runs for every 3.5 minutes of delay. If a side is unable to re-commence following the tea interval, the same rules will apply as noted above.

- 3.4.3. The team batting first may continue to bat out their overs before tea is taken, providing they have wickets in hand and the weather has not interfered with play.
- 3.4.4. In all matches that are not affected by any delay, each innings will have a maximum duration of 2 hours 30 minutes. Tea will be taken at the conclusion of the first innings, or after 2 hours 30 minutes (4.00pm) and shall last no longer than 30 minutes. The conclusion of the match shall be 2 hours 30 minutes after the commencement of the second innings (7.00pm) (See Appendix E).  
In the Premier Division and Division 1, a team who has not completed its full allocation of overs within the permitted time, shall forfeit one point for each complete over not bowled. These overs shall continue to be bowled in order to provide a conclusion of the match. There shall be no right of appeal where Umpires (as defined under Rule 1.5) have officiated. At the conclusion of the match, the Umpires shall advise the Captain of the side(s) that infringes this condition that they will be reporting the relevant details to the League.
- 3.4.5. If any innings has been completed by the first side before the due time for tea, then a 10 minute interval will be taken and play resumes until tea is taken (Refer to Law 15.3).
- 3.4.6. Tea should not exceed half an hour. Any additional time taken shall be added to the overall time of the match.
- 3.4.7. Each team will pay for 11 teas for players in league matches.
- 3.4.8. Unless otherwise stated in the Playing Conditions, no bowler may bowl more than one-fifth (1/5<sup>th</sup>) of the amount of overs scheduled for the innings, subject to ECB Regulations (see Appendix G for reduction table).

In a delayed start or interrupted match, where the overs are reduced for both sides, or for the side bowling second, no bowler may bowl more than one-fifth of the total overs allowed (unless such a number has been exceeded before the interruption), except that where the total overs are not divisible by five, an additional over shall be allowed to the minimum number of bowlers necessary to make up the balance - (e.g. after 16 overs, rain interrupts play and the innings is reduced to 32 overs. Both opening bowlers have bowled 8 overs. Two bowlers can bowl 7 and three bowlers can bowl 6. Bowlers 1 and 2 have already exceeded this limit. They count as the two bowlers who are allowed the extra overs (7 as opposed to 6), and so any other bowlers are limited to 6 overs.

Where an interruption occurs mid-over, and on resumption the bowler has exceeded the new maximum allocation, they will be allowed to finish the incomplete over.

### **3.5. GAMES AFFECTED BY WEATHER**

- 3.5.1. Both teams must report to the appointed ground whatever the prevailing weather conditions unless the visiting side is notified that conditions are unfit for play. This decision should not be taken earlier than 3 hours before the scheduled starting time. The visitors have a right to a further inspection of the ground a quarter of an hour before play is due to commence when both teams and umpire(s) will be present. Clubs refusing to fulfil such an engagement shall be dealt with as the Management Committee decide.
- 3.5.2. In the event of a game being cancelled (prior to commencement) it is the responsibility of the Club responsible for the cancellation to inform the League Secretary, the Umpires Secretary, the opposing Club Secretary and any appointed Umpire, by telephone, immediately after the decision is made. Failure to do so, the Club will be fined up to the maximum stated in Appendix D plus any Umpires fees and expenses in line with Rule 1.5.8.
- 3.5.3. In special circumstances reversed venues of league fixtures may be permissible with consent of the Management Committee, but in the event of water-logged pitches, the venue may be reversed by consent of the League Chairman or League Secretary. In all circumstances there must be mutual agreement between teams involved to the reversal of the venue. Under no circumstances will teams be allowed to play League games on days other than Saturdays.
- 3.5.4. If the start of play is delayed, or play interrupted, the umpires shall reduce the number of overs to be bowled, by each side, by one over per innings for every 7 minutes of play lost (see Appendix F).
- 3.5.5. If play is delayed or interrupted by the weather in the first innings, the Umpires shall reduce the number of overs in each innings as in Rule 3.5.4. If play is delayed or interrupted by weather in the second innings, the Umpires shall reduce the number of overs at the rate of one over for every 3.5 minutes of play lost and adjust the target total of runs in line with the number of overs remaining (see Appendix F).

- 3.5.6. If the interruption or interruptions occur after tea and the team batting second have received less than 20 overs and the match has been called off, then the match shall be deemed Abandoned. If they have received at least 20 overs then the result shall be decided based on the reduced target total of runs.
- 3.5.7. In all Divisions, Duckworth Lewis shall be used in all weather-affected matches.
- 3.5.8. In order to make maximum use of all time available in weather affected matches, umpires may recommend that the tea interval be taken early.
- 3.5.9. Once play begins after a delay or interruption, the match shall be conducted in accordance with the umpires' stated over calculations. There shall be no further revision of the over limits unless a further interruption of play occurs before tea.
- 3.5.10. If during a delay or interruption of play, the umpires calculate that there is insufficient playing time remaining for each innings to receive a minimum of 20 overs then the match shall be abandoned assuming close of play at five and a half hours after the official start time (7.00pm in all Divisions) (See Appendix E).
- 3.5.11. Assuming close of play five and a half hours after the official start time (7.00pm), the umpires shall remain at the ground until insufficient time remains for the match to be completed, unless both captains and the umpires agree that the match may be abandoned whilst sufficient time remains.

### **3.6. THE RESULT (LAW 16)**

- 3.6.1. The match shall be won by the side which scores the highest number of runs in its completed innings or in the case of a weather affected game, based on the target total calculated in accordance with Rule **Error! Reference source not found.**
- 3.6.2. A Tie will be declared when the scores are equal at the conclusion of play, but only if the side batting last has completed its innings (Refer to Laws 12 & 16) (See 3.7.7 also).
- 3.6.3. A No Result will be declared where it has not been possible to define a winning side as in 3.6.1 or a tie as in 3.6.2 and a minimum of 20 overs of the first innings has been bowled.
- 3.6.4. A game will be defined as Abandoned where play has commenced and a minimum of 5 overs of the first innings has been bowled, but the game is stopped before 20 overs of the first innings has been bowled. A game will be defined as Cancelled where no play has been possible or where a game is stopped before 5 overs of the first innings is bowled.
- 3.6.5. Points will be awarded as per the League Points System detailed in Rule 3.7.
- 3.6.6. Results of matches must be inputted onto the Play-Cricket portal by the home club by 10.00pm on the day of the match. Failing to do so will incur a fine , in accordance with Appendix D.
- 3.6.7. All detailed match results must be completed on the Play-Cricket portal, in their entirety, by the home team - listing all players who took part in the match. It is the responsibility of the away team to provide the first name and surname of all players. The result form must be fully completed by 10.00pm on the day following the match. Failing to do so will incur a fine in accordance with Appendix D, and a 5-point deduction for each third and subsequent offence.
- 3.6.8. Reports from Clubs regarding Umpires, Ground (away team only) and Fair Play must be fully completed and input onto the Play-Cricket portal by each Club not later than 10.00pm on the day following the match.

### **3.7. THE LEAGUE POINTS SYSTEM.**

- 3.7.1. 20 points are the maximum available to any side per game.
- 3.7.2. 20 points are awarded for winning the game.
- 3.7.3. Bonus points are available to the losing team and can be gained at any time during the game
- 3.7.4. Batting Points (Premier, Divisions 1 & 2):
  - 3.7.4.1. 1 point when 100 runs are scored
  - 3.7.4.2. 2 points when 125 runs are scored
  - 3.7.4.3. 3 points when 150 runs are scored
  - 3.7.4.4. 4 points when 175 runs are scored
  - 3.7.4.5. 5 points when 200 runs are scored

- 3.7.5. Batting Points (Divisions 3, 4, & 5):
- 3.7.5.1. 1 point when 50 runs are scored
  - 3.7.5.2. 2 points when 75 runs are scored
  - 3.7.5.3. 3 points when 100 runs are scored
  - 3.7.5.4. 4 points when 125 runs are scored
  - 3.7.5.5. 5 points when 150 runs are scored
- 3.7.6. Bowling Points (All Divisions):
- 3.7.6.1. 1 point when 2 wickets are taken
  - 3.7.6.2. 2 points when 4 wickets are taken
  - 3.7.6.3. 3 points when 6 wickets are taken
  - 3.7.6.4. 4 points when 8 wickets are taken
  - 3.7.6.5. 5 points when innings completed (Refer to Laws 12, 13 & 16).
- 3.7.7. Where a game is a Tie, each team will be awarded 10 points plus all bonus points accrued during the game (Refer to Laws 12 & 16) (See 3.6.2 also).
- 3.7.8. Where a game is declared a No Result (minimum 20 overs of first innings completed), both teams are awarded 10 points plus all bonus points accrued at the time the game ended.
- 3.7.9. Where a game is declared as Cancelled (no play or less than 5 overs completed) each team will receive 5 points. All bonus points that may have accrued will not be awarded.
- 3.7.10. Where a game is declared as Abandoned but 5 overs of the first innings have been bowled, each team will receive 10 points. Any bonus points that may have accrued will not be awarded.
- 3.7.11. Should a team fail to fulfil a fixture; 20 points will be awarded to the opposition and the Club fined (SNCL to decide amount). The Management Committee will address the failure of the team to complete the fixture in line with the SNCL disciplinary procedures.
- 3.7.12. Should any club scratch a match or fail to turn up as per rule 3.5.1 the club shall pay any expenses incurred by the SNCL or opposing club and be deducted 10 points.
- 3.7.13. Any Away Club cancelling a fixture less than 24 hours prior to a match will be liable for the full cost of their teas to the Home Club. Failure to reimburse the Home Club within 2 weeks of the fixture will result in the Management Committee increasing the amount owed by £10.00.

### **3.8. PROMOTION / RELEGATION**

- 3.8.1. Under normal circumstances there will be promotion of the top two teams and relegation of the bottom two teams in each division. Under no circumstances shall a Club with two teams be permitted to have both teams in the same division.
- 3.8.2. To decide on Championship, promotional and relegation issues at the end of the season in the event of teams having an equal number of points the following rule will apply:
- 3.8.3. In the event that two or more teams are tied with equal points, the team with the most wins will be deemed to be higher placed in the league. If the number of wins is also equal, the team with the most away wins will be deemed to be higher placed in the league. In the event that the teams are still tied they will play off.
- 3.8.4. If a play-off is required to decide the championship, promotion or relegation issues it will take place on the following Saturday after the last league matches at a time and venue to be decided by the Management Committee. If the game is Abandoned or a No Result then an alternative date or process will be decided by the Management Committee.
- 3.8.5. Clubs must achieve at least a 50 % mark for their pitch, outfield and facilities under the ground assessment scheme to be eligible for promotion from Division One to the Premier Division. In the event of Clubs not achieving a 50 % mark, then they may appeal to the Management Committee.

## 4. KNOCK-OUT CUP COMPETITION GENERAL RULES

### 4.1. ENTRY CRITERIA

- 4.1.1. All teams within the League are eligible to partake in all the Cup Competitions. In some cases entry will be compulsory in others it will be optional. (See specific rules for each competition).
- 4.1.2. The administration of each competition will be carried out by the Management Committee whose decision will be final in all matters.
- 4.1.3. Where appropriate, all competition matches will be played according to the League Rules except where specific Cup Competition rules take precedence.
- 4.1.4. Neutral umpires will be appointed by the Umpires Secretary for all matches (where possible). Umpires fees will be in accordance with Appendix D and will be paid expenses as per the league rules in 1.5.9. These fees will be shared between the participating clubs.

For Cup matches, the total amount claimable, including travelling expenses, will be capped at £ 25.00 per Umpire, or at £ 32.00 if only one Panel Umpire is present. For Cup finals, these amounts will be met by the League rather than by the participating Clubs.

### 4.2. TIMINGS

- 4.2.1. All matches up to and including the semi-final will be played on weekday evenings. The finals will be played on a Sunday at a time and venue to be decided by the Management Committee. Any final not played on the due date will be played on the following Sunday or at a date set by the Management Committee.
- 4.2.2. The match starting time, other than for the final, will be at 6.30pm or earlier if both teams are ready and captains agree, unless stated otherwise in the fixture list.
- 4.2.3. The toss will take place 15 minutes before the start of play, or earlier. Any side, for any match, not ready to commence at the time stated will forfeit the toss. A minimum of 7 players must be present for the fielding side at the start of the match. If there are less than 7 players in the fielding side at the start of the match, the match will be forfeited.
- 4.2.4. Each side is to use its own SNCL pink ball, except for the final where balls will be provided by the League, and each innings will consist of 20 x 6 ball overs except where the innings is completed. The duration to bowl 20 overs will be 1 hours 15 minutes.
- 4.2.5. In the case of a match affected by weather prior to commencement of play, each innings may be reduced by one over per innings for every 6 minutes of play lost, to a minimum of 10 overs per innings. No reduction in overs shall be permitted once play has commenced. In such cases, the allowance of overs per bowler shall be reduced by 1 over for every 5 overs play is reduced.

Innings Duration (overs)	Innings Duration		Maximum Overs per Bowler
	Hours	Mins	
20	1	15	4
19	1	12	4
18	1	8	4
17	1	4	4
16	1	0	4
15	0	57	3
14	0	53	3
13	0	49	3
12	0	45	3
11	0	42	3
10	0	38	2

- 4.2.6. In the case of rain affected matches, that are not able to be completed on the dates specified, it is the Clubs' responsibility to arrange a replay in order to produce a winning team before the next round of each competition. The League Secretary and Umpires Secretary must be informed of the re-arrangement as soon as possible.
- 4.2.7. Should a Club have two teams drawn in a Cup match on the same date, the first team fixture will take precedence with the second team being arranged between the two competing Clubs on a mutually convenient date, prior to the date set for the next round of the Competition. The Management Committee will decide on the date for the rearranged fixture should Clubs fail to agree.
- 4.2.8. Only County Cup games will take precedence over Cup games (i.e. Northants, Oxon, Bucks, Warwicks).
- 4.2.9. There shall only be one replay per cup tie. If a result is not achieved on the replay date, the result shall be decided by a bowl off in line with the regulations set out in section 4.8 below. If a bowl off is not possible, the result shall be decided by the toss of a coin.

### **4.3. ELIGIBILITY OF PLAYERS**

- 4.3.1. All players, in all Knock-Out Competitions, must be registered SNCL players. In addition, they must have played in at least one League game for their Club in the season of the competition and prior to the cup fixture. If the player has not played in a League fixture prior to the cup fixture, they must have played three League fixtures in the previous season for the Club, and not represented any other Clubs outside the SNCL in the current season.
- 4.3.2. A Player who plays or has played for another team outside the SNCL on a Saturday must have played three League matches for the competition Club prior to the cup fixture in the current season. This Rule does not apply to players in full time education who are registered to play in the SNCL.
- 4.3.3. An 'A' Team may field a maximum of three players who have played five League matches or more with their Club's First Team during that season (or any of the Club's teams playing outside the SNCL on a Saturday) during that season.
- 4.3.4. Any First team not playing in the SNCL with an 'A' Team in the SNCL, Rule **Error! Reference source not found.** will not apply.
- 4.3.5. A player shall only be eligible to play for one Club in any Cup Competition in any one season.
- 4.3.6. Disciplinary action will be taken against any team fielding an ineligible player. The onus is on the Club making the objection to provide suitable evidence that a player is not eligible. The League will not investigate where there is an allegation which is not supported by evidence.

### **4.4. COMPETITION MATCH RESULTS**

- 4.4.1. The match will be won by the side which scores the higher number of runs in its innings. In a match where the runs and the wickets lost are identical; a tie or draw will be declared. Where a match ends with the scores level, the side which has lost the fewer wickets shall be declared the winner (Refer to Laws 12.1, 12.3, 21.4 and 21.5).
- 4.4.2. Where a match ends in a tie or draw, the venue will be reversed for the replay.
- 4.4.3. Finals, where played on neutral ground, will be replayed, if possible, on the same ground.

### **4.5. FINANCIAL GAINS**

- 4.5.1. Any financial gains from fund raising activities such as gate admission charges, raffle receipts, bar takings etc. shall go to the host Club funds.

### **4.6. SPECIFIC LAW REQUIREMENTS**

- 4.6.1. White clothing must be worn.
- 4.6.2. No bowler is allowed to bowl more than four overs in any one match.
- 4.6.3. Any ball passing down the leg-side of the wicket shall be deemed a 'wide-ball' (all other parts of Law 25 of the Laws of Cricket apply).
- 4.6.4. A delivery of a 'No-Ball' (Law 24) will result in a 'free-hit' on the replacement delivery (See definition of Free-Hit in Appendix M).

- 4.6.5. Fielding restrictions - a 30 yard (27 metre) radius fielding circle shall be used for all matches. The fielding circle will be marked by white discs (see Appendix C). At the instance of delivery, the wicket-keeper plus four fielders must be within the fielding circle. The penalty for not having enough fielders in the fielding circle is a 'No-Ball' and subsequent free-hit.
- 4.6.6. Timed Out - the incoming batsman must be in a position to take guard, or for his partner to be ready to receive the next ball, within 2 minutes of the fall off the previous wicket. Any infringement of this rule shall result in the incoming batsman being declared out by the Umpires.
- 4.6.7. Short-pitched deliveries - the bowler shall be limited to one short pitch delivery per over. The short pitched delivery is defined as bouncing over shoulder height, but below head height, of the batsman. Repetition of a short pitched delivery will result in a 'No-Ball' and subsequent free-hit. A delivery above head height shall also be called a wide ball.

#### **4.7. OVER-RATE PENALTIES**

- 4.7.1. A six-run penalty shall apply for each over not bowled in the required time, as determined by the Umpires.
- 4.7.2. All sides are expected to be in a position to bowl the first ball of the last of their 20 overs within 1 hours 15 minutes playing time (or otherwise as reduced).
- 4.7.3. 20 overs shall be bowled and the penalty runs are then added to the final total.
- 4.7.4. Umpires are instructed to apply a strict interpretation of time wasting by the batsmen (5 penalty runs) specifically; batsmen are expected to be ready for the start of the new over as soon as the bowler is ready.

#### **4.8. BOWL-OFF REGULATIONS**

- 4.8.1. Five players from each side will bowl over-arm, two deliveries each at a wicket (conforming to Law 8) from a wicket (conforming to Law 8) pitched at a distance of 22 yards with, if practicable, bowling, popping and return creases (conforming to Law 9).
- 4.8.2. The first bowler from Team A will bowl two deliveries, then the first bowler from Team B will bowl two deliveries, and then the second bowler from Team A will bowl two deliveries, and so on.
- 4.8.3. The side which bowls down the wicket (as defined in Law 8.1) will be the winner.
- 4.8.4. If the scores are equal, the same players will bowl one ball each alternately to achieve a result on a 'sudden death' basis (the order in which the bowlers bowl in the sudden death may differ from the first stage of the bowl out).
- 4.8.5. If circumstances make the bowl out impossible, the match shall be decided by the toss of a coin.
- 4.8.6. The same suitably acceptable ball (not a new one) will be used by both teams. If this ball becomes wet, it may be changed subject to the Umpires' approval.
- 4.8.7. If a bowler bowls a 'no-ball', it will count as one of his two deliveries but will not count towards the score of the team.
- 4.8.8. Each side will appoint a wicket-keeper to stand behind the wicket but out of reach of the stumps.

## **5. SNCL DIVISIONAL CUP RULES**

### **5.1. ENTRY CRITERIA**

5.1.1. Entry into the Competition is optional for all clubs within the SNCL.

### **5.2. COMPETITION FORMAT**

5.2.1. The Competition will consist of teams in their respective Divisions playing each other on a straight knock-out basis.

### **5.3. ELIGIBILITY OF PLAYERS**

5.3.1. Those clubs entering more than one team in the SNCL should pay particular attention to the Competition General Rules concerning eligibility and registration of players.

### **5.4. BOWLERS' OVERS**

5.4.1. No bowler is allowed to bowl more than four overs in any match.

### **5.5. TIMINGS**

5.5.1. All matches up to and including the semi-finals and area finals will be played on Thursday evenings. The final will be played on a Sunday at a time and venue to be decided by the Management Committee.

5.5.2. All other timings are as detailed in Section 4 - Knock-Out Cup Competition General Rules.

### **5.6. MAN OF THE MATCH**

5.6.1. There will be a Man of the Match award in each final.

5.6.2. The adjudicator will be the Chairman of the SNCL or members of the Management Committee.

## **6. WARDINGTON CUP COMPETITION RULES**

### **6.1. ENTRY CRITERIA**

- 6.1.1. Entry to the Competition is optional for all clubs within the SNCL.
- 6.1.2. The Management Committee may, at their discretion, invite Clubs outside of the SNCL where they have previously been a member of the SNCL.

### **6.2. COMPETITION FORMAT**

- 6.2.1. Depending on the number of teams entering the Competition various rounds will be played until the final decides the eventual winner.

### **6.3. ELIGIBILITY OF PLAYERS**

- 6.3.1. Those clubs entering more than one team in the competition should pay particular attention to the Competition General Rules concerning eligibility and registration of players.
- 6.3.2. Disciplinary action will be taken against any team fielding an ineligible player.

### **6.4. BOWLER'S OVERS**

- 6.4.1. No bowler is allowed to bowl more than four overs in any one match.

### **6.5. TIMINGS**

- 6.5.1. All matches up to and including the semi-final will be played on Tuesday evenings. The Final will be played on a Sunday at a time and venue to be decided by the Management Committee.
- 6.5.2. All other timings are as detailed in Section 4 - Knock-Out Cup Competition General Rules.

### **6.6. MAN OF THE MATCH**

- 6.6.1. There will be a Man of the Match award in the final.
- 6.6.2. The adjudicator will be the Chairman of the SNCL or members of the Management Committee.

## **APPENDIX A: DISCIPLINARY PROCEDURES**

For information regarding disciplinary procedures, please refer to the ECB General Conduct Regulations.

All discipline relating to breaches of the Laws of Cricket shall be dealt with by the Northamptonshire County Cricket Board through their Disciplinary Officer (co-ordinated via the SNCL Disciplinary Co-ordinator).

Breaches of League Rules will be dealt with via the SNCL Management Committee.

**APPENDIX B: THE WICKETS (Law 8)**

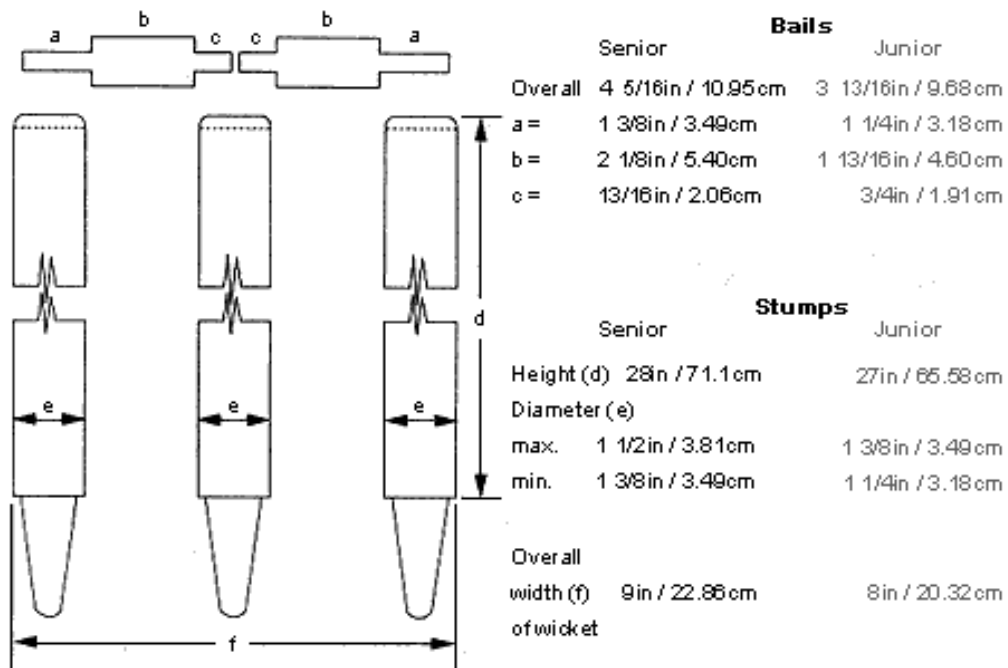

**1. Width and pitching**

Two sets of wickets shall be pitched opposite and parallel to each other at a distance of 22 yards/20.12m between the centres of the two middle stumps. Each set shall be 9 in/22.86cm wide and shall consist of three wooden stumps with two wooden bails on top.

**2. Size of stumps**

The tops of the stumps shall be 28 in/71.1cm above the playing surface and shall be dome shaped except for the bail grooves. The portion of a stump above the playing surface shall be cylindrical, apart from the domed top, with circular section of diameter not less than 1 3/8 in/3.49cm nor more than 1 1/2 in/3.81cm.

**3. The Bails**

- (a) The bails, when in position on the top of the stumps,
  - (i) shall not project more than 1/2 in/1.27cm above them.
  - (ii) shall fit between the stumps without forcing them out of the vertical.

- (b) Each bail shall conform to the following specifications.

Overall length:- 4 5/16 in / 10.95cm	Length of barrel:- 2 1/8 in / 5.40cm
Longer spigot:- 1 3/8 in / 3.49cm	Shorter spigot:- 13/16 in / 2.06cm

**4. Dispensing with Bails**

The umpires may agree to dispense with the use of bails, if necessary. If they so agree, then no bails shall be used at either end. The use of bails shall be resumed as soon as conditions permit.

**APPENDIX C: THE PITCH (Law 6), THE BOWLING, POPPING AND RETURN CREASES (Laws 7.2, 7.3, 7.4, 9.5) AND THE PROTECTED AREA (Law 41.11).**

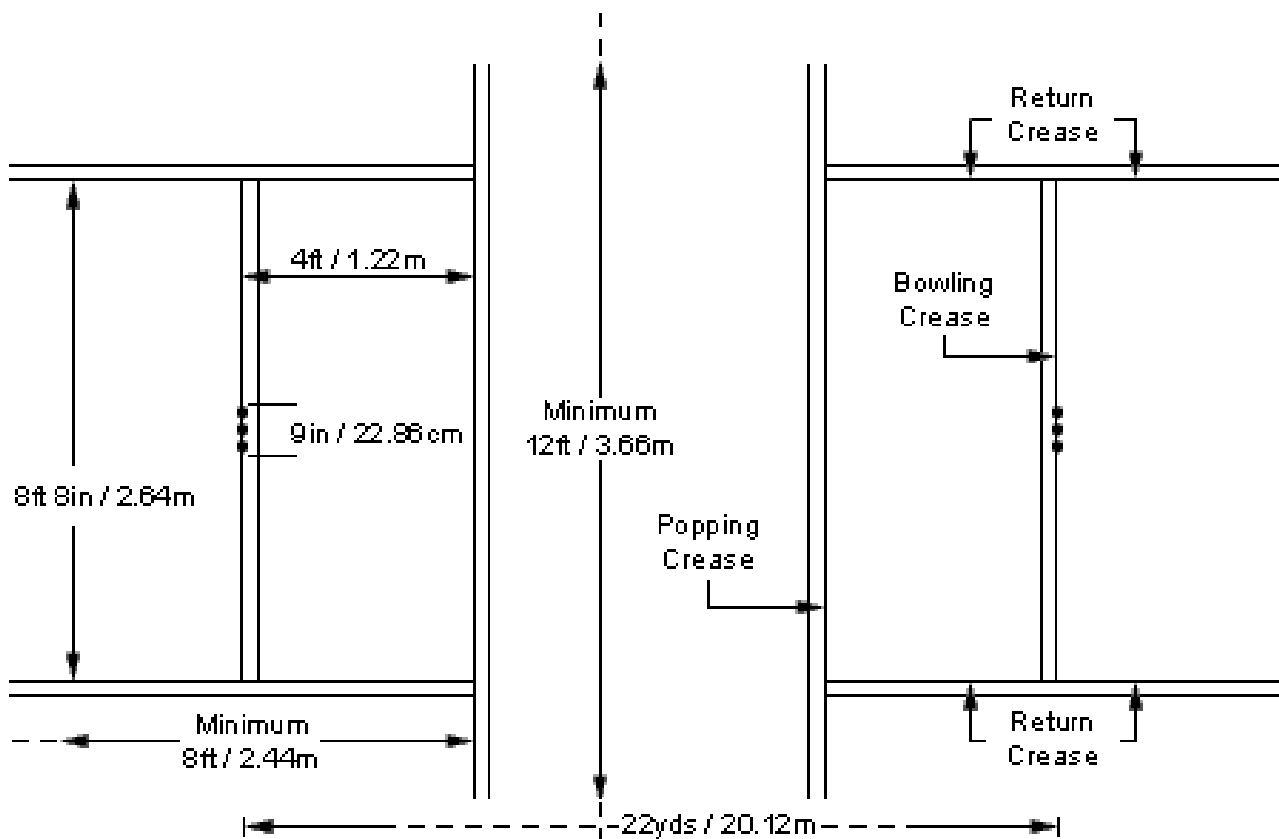

**1. The Creases:**

A bowling crease, a popping crease and two return creases shall be marked in white, as set out in 2, 3 and 4 below, at each end of the pitch.

**2. The Bowling Crease:**

The bowling crease, which is the back edge of the crease marking, shall be the line through the centres of the three stumps at that end. It shall be 8ft 8 in/2.64m in length, with the stumps in the centre.

**2. The Popping Crease:**

The popping crease, which is the back edge of the crease marking, shall be in front of and parallel to the bowling crease and shall be 4ft/1.22m from it. The popping crease shall be marked to a minimum of 6ft/1.83m on either side of the imaginary line joining the centres of the middle stumps and shall be considered to be unlimited in length.

**3. The Return Creases:**

The return creases, which are the inside edges of the crease markings, shall be at right angles to the popping crease at a distance of 4ft 4 in/1.32m either side of the imaginary line joining the centres of the two middle stumps. Each return crease shall be marked from the popping crease to a minimum of 8ft/2.44m behind it and shall be considered to be unlimited in length.

**4. The Protected Area Markings:**

An area of the pitch to be referred to as the protected area is defined as that area contained within a rectangle bounded at each end by imaginary lines parallel to the popping crease and 5 feet in front of each and on the sides by imaginary lines, one each side of the imaginary line joining the centres of the two middle stumps, each parallel to it and one foot from it.

**5. Re-Marking Creases:**

Creases shall be re-marked whenever either Umpire considers it necessary.

**6. Fielding Circle Dimensions (Cup Competitions)**

Two semi-circles shall be drawn on the field of play.

An oval shall be made by drawing two semi-circles on the field of play. The semi-circles shall have as their centre - the middle stump at either end of the pitch. The radius of each of the semi-circles shall be 30 yards (27 metres). The semi-circles shall be linked by lines with are drawn parallel to the pitch.

The field restriction area should be marked by painted white 'dots' at five-yard intervals, each 'dot' to be covered by a white plastic or rubber (but not metal) disc measuring seven inches in diameter.

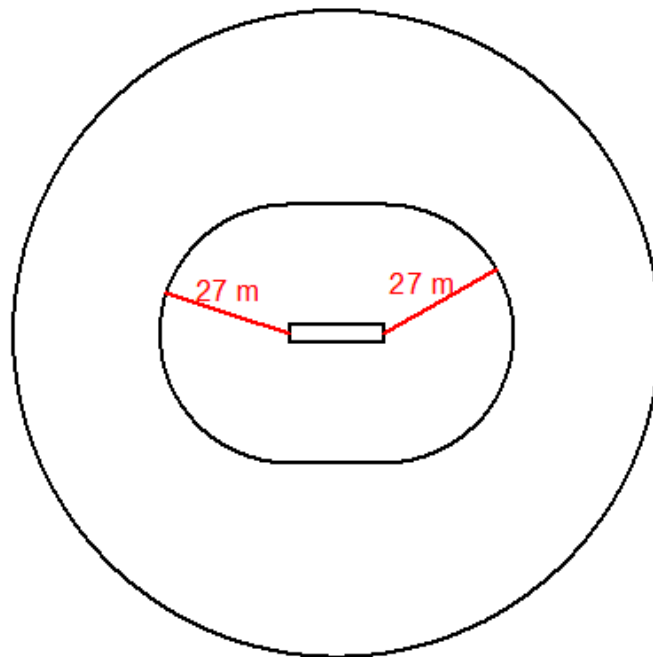

## APPENDIX D: SCHEDULE OF FEES & FINES

Description of Fee	Value	Rule
League: 1st Team Joining Fee	£ 45.00	1.3.14
League: Extra Teams Joining Fee	£ 35.00	1.3.14
Match Teas Fee (Per Team) (Maximum)	£ 40.00	1.3.18
League: Umpires Fees 2 Umpires (per Umpire)	£ 25.00	1.5.9
League: Umpires Fees 1 Umpire	£ 40.00	1.5.9
Umpires Travelling Expenses	£0.45p Per Mile Minimum £5.00	1.5.7
Player Transfer Fee	£ 5.00	1.6.4
Cups: Entry Fee	£ 15.00	1.3.13
Match Balls (League & Cup)	£ 14.00	3.2.2
Cups: Umpires Fees (One Umpire (Maximum))	£ 25.00 (plus mileage to a maximum of £ 32.00)	4.1.4
Cups: Umpires Fees (Two Umpires (Maximum))	£ 18.00 (plus mileage to a maximum of £ 25.00)	4.1.4

Description of Fine	1st Offence	2nd Offence	3rd & Subsequent Offence	Rule
Withdrawal from League on or after 1st March	£ 50.00			1.3.9
Late Payment of Joining Fee 1st Team	£ 35.00			1.3.14
Late Payment of Joining Fee Extra Team	£ 25.00			1.3.14
Non-Attendance at AGM, EGM, Ball / Handbook Collection evening or Pre-Season Briefing	£ 20.00			1.4.11
Playing an Ineligible Player	£ 20.00 per Player and Match Awarded to Opposition			1.6.5
Late Return of Trophies	£ 50.00			1.8.3
Failing to Supply Correct Match Balls	£ 20.00			3.2.6
Failing to Correctly Mark Out Playing Area	By Management Committee & Possible Points Deduction.			3.3.3
No Notification of Cancelled Fixture	Up to £ 30.00			3.5.2
No Result Phoned In	£ 10.00	£ 20.00	£ 30.00	3.6.6
Late Posting of Result	£ 5.00	£ 10.00	£ 20.00 and a 5 Point Deduction	3.6.7
Scratching Fixture	Fine, Expenses, Match Awarded to Opposition and Deduction of 10 Points.			3.7.11
Failing to Reimburse Teas Fees to Home Club following late cancellation	£ 10.00			3.7.12

**APPENDIX E: EXAMPLE OF MATCH TIMINGS (STANDARD & REDUCED TO 20 OVERS)**

**LEAGUE DIVISIONS (ALL)**

	<b>Standard</b>	<b>Minimum 20 Overs</b>
Toss At	1.15pm	4.15pm
Match Start	1.30pm	4.30pm
Tea / Interval	4.00pm	5.40pm
Interval	30 Minutes	10 Minutes
Re-Start	4.30pm	5.50pm
Finish of Play	7.00pm	7.00pm

**APPENDIX F: *Reserved for Duckworth Lewis Information***

## APPENDIX G: TABLE OF BOWLER'S OVERS ALLOWANCES

The following table indicates the maximum number of overs a bowler can bowl when, during an affected match the total overs being played have been reduced, as detailed in rule 3.4.8.

<b>Total Overs</b>	<b>Maximum Per Bowler</b>	<b>Bowlers Overs Split</b>
40	8	5 bowlers x 8 overs max. each
39	7	7 overs max. - 4 bowlers can bowl 8 overs
38	7	7 overs max. - 3 bowlers can bowl 8 overs
37	7	7 overs max. - 2 bowlers can bowl 8 overs
36	7	7 overs max. - 1 bowler can bowl 8 overs
35	7	5 bowlers x 7 overs max. each
34	6	6 overs max. 4 bowlers can bowl 7 overs
33	6	6 overs max. 3 bowlers can bowl 7 overs
32	6	6 overs max. 2 bowlers can bowl 7 overs
31	6	6 overs max. 1 bowler can bowl 7 overs
30	6	5 bowlers x 6 overs max. each
29	5	5 overs max. - 4 bowlers can bowl 6 overs
28	5	5 overs max. - 3 bowlers can bowl 6 overs
27	5	5 overs max. - 2 bowlers can bowl 6 overs
26	5	5 overs max. - 1 bowler can bowl 6 overs
25	5	5 bowlers x 5 overs max. each
24	4	4 overs max. - 4 bowlers can bowl 5 overs
23	4	4 overs max. - 3 bowlers can bowl 5 overs
22	4	4 overs max. - 2 bowlers can bowl 5 overs
21	4	4 overs max. - 1 bowler can bowl 5 overs
20	4	5 bowlers x 4 overs max. each

---

## APPENDIX H: ECB REGULATIONS REGARDING YOUNG PLAYERS IN ADULT CRICKET

### 1. ECB Guidelines for Junior Players in Open Age Cricket

These guidelines cover the selection and participation of young players in open age cricket. They are designed to help Clubs to decide when to select young players in open age cricket and how best to help their cricketing development when they play within open age groups. They apply to boys and girls equally. Age groups are based on the age of the player at midnight on 31<sup>st</sup> August in the year preceding the current season.

#### Guidance for Clubs and Leagues

All clubs must recognise that they have a duty of care towards all young players who are representing the club. This duty of care also extends to Leagues that allow the participation of young players in open age groups in their League. The duty of care should be interpreted in two ways:

- Not to place a young player in a position that involves an unreasonable risk to that young player, taking account of the circumstances of the match and the relative skills of the player.
  - Not to create a situation that places members of the opposing side in a position whereby they cannot play cricket as they would normally do against adult players. In addition, the following specific requirements apply to young players in open age cricket.
1. Making the step up from junior to open age cricket is a significant event in any player's cricket experience. Ensure that the player's safety, personal development needs and overall cricket experience are considered.
  2. There is no definitive age at which they should be introduced to open age cricket but determine each case on an individual basis dependent on their ability and stage of cognitive and emotional maturity to take part at this level, taking into account the requirement that no Junior Cricketers younger than the age group of under 13 can play in open age cricket.
  3. ECB Fast Bowling Directives and Fielding Regulations should always be adhered to for junior players in open age cricket. All young players who have not reached their 18th birthday must wear a helmet with a faceguard when batting and either a helmet or faceguard when standing up to the stumps when keeping wicket. A young player acting as a runner must also wear a helmet even if the player they are running for is not doing so.
  4. Any player in the Under 13 age group must have explicit written consent from a parent or guardian before participating in open age cricket. Clubs must ensure that their player registration procedures ensure that consent is obtained.
  5. Provide an opportunity for players to show their talents in an appropriate way. Children who are just used as fielders will not fully experience the game.
  6. Be supportive at all times for all forms of effort even when children are not successful. Try and put them in situations where they will experience some success (however small) and ensure plenty of praise and encouragement.
  7. Try and involve them in all aspects of the game wherever possible i.e. socializing, team talks, practice, decision making etc. so that they feel part of the team.
  8. Children will often feel more comfortable and able to perform if they have a family member or friend also playing in the side.
  9. Remember, children's early experiences will remain with them always and will often determine whether they want to remain playing the game or give up and do something else!
  10. Clubs and Leagues can apply more strict restrictions on the participation of young players in open age cricket at their discretion. It is strongly recommended that a parent, guardian, or other identified responsible adult is present whenever a player in the Under 13 age group plays open age cricket. This could include the captain or other identified adult player taking responsibility for the young player.

## 2. ECB Fast Bowling Match Directives (April 2025)

Age	Max. Overs Per Spell	Max. Overs Per Day
11 and Below	4 Overs Per Spell	8 Overs Per Day
12, 13	5 Overs Per Spell	10 Overs Per Day
14, 15	5 Overs Per Spell	12 Overs Per Day
16, 17	6 Overs Per Spell	15 Overs Per Day
18, 19	7 Overs Per Spell	18 Overs Per Day



For the purposes of these Directives a fast bowler is defined as a bowler to whom a wicket keeper in the same age group would in normal circumstances stand back to take the ball.

Having completed a spell the bowler cannot bowl again, from either end, until the equivalent number of overs to the length of his\* spell have been bowled from the same end. A bowler can change ends without ending his current spell provided that he bowls the next over that he legally can from the other end. If this does not happen his spell is deemed to be concluded.

If play is interrupted, for any reason, for less than 40 minutes any spell in progress at the time of the interruption can be continued after the interruption up to the maximum number of overs per spell for the appropriate age group. If the spell is not continued after the interruption the bowler cannot bowl again, from either end, until the equivalent number of overs to the length of his spell before the interruption have been bowled from the same end. If the interruption is of 40 minutes or more, whether scheduled or not, the bowler can commence a new spell immediately.

In matches of 20 overs or less per team where the competition regulations only allow bowlers to bowl less than or equal to the number of overs specified as the maximum in a spell in the Directives the provisions requiring an equivalent number of overs from the same end to have elapsed before a subsequent spell can commence shall not apply (e.g. in any age group competition where a maximum of 4 overs per bowler is allowed these may be bowled at any time in the innings irrespective of the number of spells bowled).

Once a bowler covered by these Directives has bowled in a match, he cannot exceed the maximum number overs per day for his age group even if he subsequently bowls spin. He can exceed the maximum overs per spell if bowling spin but cannot then revert to bowling fast until an equivalent number of overs to the length of his spell have been bowled from the same end. If he bowls spin without exceeding the maximum number of overs in a spell the maximum will apply as soon as he reverts to bowling fast.

Captains, Team Managers and Umpires are asked to ensure that these Directives are followed at all times.

**For guidance, it is recommended that in any 7 day period a fast bowler should not bowl more than 4 days in that period and for a maximum of 2 days in a row.**

\*Any reference to he/his should be interpreted to include she/her.

Age groups are based on the age of the player at midnight on 31<sup>st</sup> August in the year preceding the current season.

### 3. ECB Guidance on the Wearing of Helmets (April 2023)

The England and Wales Cricket Board has issued new safety guidance on the wearing of cricket helmets by young players.

- Guidance on wearing helmets for younger players
- Guidance on wearing helmets for fielders
- Guidance of responsibilities of instructors
- Guidance of responsibilities of umpires
- Helmet guidance for manufacturers (including list of current suppliers)

In recent years it has become more common for professional cricketers and those playing a high standard of recreational cricket to wear a helmet when batting, particularly against faster bowling. Helmets have become more widely available and are now covered by a British Standard.

Many of the cricketing bodies responsible for the cricket played by young players already either recommend or insist that helmets are worn. The ECB wishes to establish a consistent and safe approach in all junior cricket. This section and the linked pages addresses the many issues involved.

#### NEW GUIDANCE

It is mandatory that a helmet is worn by young players when batting and when standing up to the stumps when keeping wicket against a hard cricket ball in matches and in practice.

A young player should not be allowed to bat or to stand up to the stumps when keeping wicket without a helmet against a hard ball. Coaches, teachers, managers and umpires should always ensure that a young player wears a helmet.

Players should regard a helmet with a faceguard as a normal item of protective equipment when batting against a hard ball, together with pads, gloves and, for boys, an abdominal protector (box).

There is a British Standard (BS7928:1998) for cricket helmets and it is in the best interests of players to ensure that their helmet conforms to this standard.

In law a young person is deemed to become an adult at age 18. The law also imposes a duty of care on those responsible for minors (i.e. those under the age of 18). The ECB is recommending that this guidance is followed by all players up to the age of 18. It applies to young players in adult cricket as well as to all junior cricket played with a hard ball.

### 4. ECB Fielding Regulations

The following are taken from the 2023 Regulations and Playing Conditions:

- No young player in the Under 15 age group or younger shall be allowed to field closer than 8 yards (7.3 metres) from the middle stump, except behind the wicket on the off side, until the batsman has played at the ball.
- For players in the Under 13 age group and below the distance is 11 yards (10 metres).
- These minimum distances apply even if the player is wearing a helmet.

- Should a young player in these age groups come within the restricted distance the umpire must stop the game immediately and instruct the fielder to move back.
- In addition, any young player in the Under 16 to Under 18 age groups, who has not reached the age of 18, must wear a helmet and, for boys, an abdominal protector (box) when fielding within 8 yards (7.3 metres) of the bat, except behind the wicket on the off side. Players should wear appropriate protective equipment whenever they are fielding in a position where they feel at risk.
- These fielding regulations are applicable to all cricket in England and Wales. Age groups are based on the age of the player at midnight on 31st August in the year preceding the current season.

## 5. Consequences of Non-Compliance

Any reference to 'Captain' below means (a) in Open Age Cricket, the person acting as the captain of the team from time to time; and (b) in Junior Cricket, the Team Manager.

### Where an Appointed Umpire is officiating:

- 5.1 If at any time a Junior Cricketer takes their position in the field in breach of the applicable minimum fielding distance outlined in Regulation 2.2.1, the standing umpire at the bowler's end must stop the game and inform the Junior Cricketer and their Captain that the Junior Cricketer must move back until they comply with the applicable minimum fielding distance.
- 5.2 If the Junior Cricketer refuses to comply with the umpire's request, the umpire concerned must deem the fielder to be wasting time and, if the ball is in play, call and signal dead ball, and inform the other umpire. The umpire concerned must then warn the Captain of the fielding side, indicating that this is a first and final warning, and must inform the batters.
- 5.3 If the Junior Cricketer still refuses to comply with the umpire's request, the umpire concerned must deem this a further waste of time and must inform the other umpire. The umpire concerned must then award 5 penalty runs to the batting side and inform the Captain of the fielding side of the reason for this action (in accordance with Law 41.9).
- 5.4 If following the imposition of this penalty the Junior Cricketer still refuses to comply with the umpire's request, the umpire concerned must deem this as the fielding side refusing to play and award the match to the batting side (in accordance with Law 16.3.1.2).

### Where an Appointed Umpire is not officiating:

- 5.5 If at any time a Junior Cricketer takes their position in the field in breach of the applicable minimum fielding distance outlined in Regulation 2.2.1, the Acting Umpire must stop the game and inform the Junior Cricketer and their Captain that the Junior Cricketer must move back until they comply with the applicable minimum fielding distance.
- 5.6 The Acting Umpire must not continue the game until the Junior Cricketer complies with their request. If the Acting Umpire allows play to continue despite the Junior Cricketer not complying with their request, or in circumstances where the Acting Umpire has not requested that the Junior Cricketer move back, the Captain of the batting team must not allow their batters to face another delivery until the Junior Cricketer has moved back. If play does not resume within 15 minutes, the game must be deemed forfeited by the fielding team and awarded to the batting team.

## APPENDIX I: CHILD PROTECTION

### ARE YOU LIABLE?

It is said that evil succeeds when good men do nothing. There are thousands of good men and women in cricket. Their efforts are testament in the fact that the sport continues to thrive week in week out, year in year out.

However, in this country we have freedom of speech, freedom of movement and free access to children. For every good man and woman doing good things there is an 'evil'. The evil exists in that one person who gives up their time not for the love of cricket but for the love of children.

As a parent would you invite a stranger into your home to look after your child without vetting their suitability? No, then why allow it to happen at a cricket club?

As a volunteer in cricket you are not absolved of your parental responsibilities. As a parent in cricket you have responsibilities as a volunteer. So why are there a number of clubs not taking their child protection responsibilities seriously?

All cricket clubs are desperate for volunteers but does that mean we overlook screening their suitability to come in contact with children because we are distracted by our need for another pair of hands?

Any club that invites persons under the age of 18 to partake in cricket outside their home environment; or relies upon such persons to provide a foundation, upon which their club is constructed, has an irrefutable responsibility to safeguard the welfare and safety of those young people.

For a long time cricket has ignored child welfare and protection. However, just because there is a slow awakening of consciousness does not mean that cricket is uncovering a new problem. Issues in relation to child abuse in sport and cricket have always existed but at the end of the day it comes down to whether it has had direct implications for you, your club or your child.

Child-protection legislation in the UK stipulates that organisations and individuals involved with children and young people have a duty to protect them from all foreseeable and perceived harm.

British law states that an individual or group is guilty of an offence if they knowingly 'offer work (paid or voluntary) to or fail to remove an individual from work with children' if they have certain previous convictions. This offence carries a prison sentence. This does not even take into consideration the fact that an individual or group can be subject to civil litigation if a child is abused in their care.

Every club has a 'Duty of Care' to fulfil. This means that clubs must do all that they can to protect children in their 'care' or liability sits solely and squarely with that club and those that run it.

Whether or not clubs are run as a business is neither here nor there. Liability in the eyes of the law is exactly the same.

What can you do to reduce this liability? Making a decision to change the focus of your club toward protecting children is the first step in recognizing that this matter will not go away. Child abuse is like alcoholism – if you don't acknowledge that there is a problem how can you tackle it.

Accessibility to Criminal Records Bureau (CRB) checks in cricket has never been easier. All coaches, umpires, scorers and age group managers should be CRB checked. All other volunteers in your club must be asked to complete a Self Declaration form (available at [www.ecb.co.uk](http://www.ecb.co.uk) or [www.play-cricket.com](http://www.play-cricket.com)) Remember that the CRB process is only one

part of a comprehensive vetting procedure. Information and references from an individual's previous cricket club or trusted professional are another method.

Adopting and actually implementing the guidance in 'Safe Hands – Welfare of Young People in Cricket' policy and appointing a Club Welfare Officer assist to lessen liability and work toward complying with your duty of care.

Children themselves are your biggest asset in eradicating this problem. By simply asking the young people in your club what they are experiencing and how you can work together to resolve issues will ensure a comprehensive and commendable approach. Furthermore, remember that a parent is not absolved of their responsibilities simply because their child is at your club.

When Lord Harris stated "You do well to love cricket for it is more free from anything sordid, anything dishonourable than any game in the world." He couldn't have possibly realised the reality that a club is facing when it attracts children who may be on the 'Child Protection' register, abused at home or vulnerable, whilst at the same time attracting someone who wishes to exploit that vulnerability and abuse it.

If we are to "protect it from anything that will sully it, so that it may grow in favour with all men" we all must realise that naivety and ignorance are not an excuse either in law or morally. Your defence is positive action.

If you require further information please go to [www.ecb.co.uk](http://www.ecb.co.uk) or contact your County Welfare Officer.

Rebecca Ledingham  
ECB Child Protection Manager

## APPENDIX J: ECB GUIDELINES FOR DISCLOSURE AND BARRING SERVICE CHECK REQUIREMENTS (DBS) IN CRICKET

ROLE	DISCLOSURE AND BARRING SERVICE CHECK (DBS)	SELF DECLARATION REQUIRED	SELF DECLARATION RECOMMENDED	COMMENTS
ACTIVE VOLUNTEER		YES		DBS IF REGULAR, UNSUPERVISED, SOLE ACCESS
ADULT TEAM CAPTAINS		YES		DBS IF JUNIOR PLAYERS PLAYING REGULARY
ADULT PLAYERS			YES	SELF DEC IF JUNIOR PLAYERS PLAYING REGULARY
AGE GROUP MANAGER	YES			
ASSISTANT COACH		YES		IF UNQUALIFIED
ASSISTANT GROUNDSMAN		YES		
ASSISTANT SECRETARY			YES	
ASSISTANT TREASURER			YES	
BAR MANAGER		YES		DBS IF REGULAR, UNSUPERVISED, SOLE ACCESS
CHAIRMAN			YES	
CHAIRMAN OF CRICKET			YES	
CHAIRMAN OF JUNIOR CRICKET		YES		DBS IF COACHING
CLUB CAPTAIN			YES	MAY NOT BE 1ST XI CAPTAIN
CLUB DEVELOPMENT OFFICER		YES		DBS IF COACHING
CLUB OFFICE MANAGER			YES	
CLUB UMPIRE	YES			
COLTS MANAGER	YES			
COMMITTEE MEMBER			YES	
FIRST AIDER *		YES		DBS IF REGULAR, UNSUPERVISED, SOLE ACCESS
FIXTURE SECRETARY			YES	
GROUND CHAIRMAN			YES	
GROUNDSMAN		YES		
HOUSE SECRETARY			YES	
MEMBERSHIP SECRETARY			YES	
PATRON			YES	DEPENDING ON INVOLVEMENT
PRESIDENT			YES	DEPENDING ON INVOLVEMENT
QUALIFIED COACH VOLUNTEER OR PROFESSIONAL COACH	YES			

REGISTRATION SECRETARY			YES	
RESULTS SECRETARY			YES	
SCORER (ACUS)	YES			
SECRETARY		YES		
TEA LADY/CATERER		YES		DBS IF REGULAR, UNSUPERVISED, SOLE ACCESS
TEAM SECRETARY		YES		
TREASURER			YES	
UMPIRE – LEAGUE PANEL	YES			
VICE CHAIRMAN			YES	DEPENDING ON INVOLVEMENT
VICE PRESIDENT			YES	DEPENDING ON INVOLVEMENT
WEB SITE ADMINISTRATOR		YES		
WELFARE OFFICER	YES			CLUB/LEAGUE/COUNTY

PLEASE NOTE THAT THIS LIST HAS BEEN DEVELOPED AS GUIDANCE FOR CLUBS BUT CLUB WELFARE OFFICERS WILL NEED TO ASSESS THE ROLE OF INDIVIDUALS WITHIN THE CLUB IN MAKING A DECISION ON WHETHER OR NOT TO REQUIRE A DBS CHECK.



- INCLUDING PHYSIOTHERAPIST AND SIMILAR STAFF IN WORKING DIRECTLY WITH YOUNG PEOPLE ON BEHALF OF THE CLUB / SCHOOL/ LEAGUE / COUNTY CLUB OR BOARD.
- DBS CHECKS TO BE DONE THROUGH ECB VIA CLUB SAFEGUARDING OFFICER.
- SELF DECLARATION FORMS TO BE DONE THROUGH CLUB SAFEGUARDING OFFICER – CONTACT CLUB DIRECTLY.

## APPENDIX K: SNCL UMPIRE'S REPORT FORM

**Fixture:** ..... Vs .....

**Type of Fixture:** League / Cup / Other (delete as necessary)

**Played at:** .....

**Date:** .....

**Report Details:**

**Player(s) Involved:** .....

**From Club:** .....

Is hereby reported for infringement of the following Laws: ( tick as appropriate )

- Law 2.6 Player Returning to the Field Without Permission
- Law 18.5 Deliberate Short Running
- Law 21.2 Bowler Throwing
- Law 28.2 Illegal Fielding of the Ball
- Law 41.3 Changing the Condition of the Match Ball
- Law 41.4 Deliberately Attempting to Distract Striking Batsman Preparing to / or Receiving a Delivery
- Law 41.5 Deliberately Distracting / Obstructing a Batsman (after a delivery)
- Law 41.6 Bowling of Dangerous and Unfair Deliveries
- Law 41.7 Bowling of Deliberate High Full-Pitched Balls
- Law 41.8 Bowling of Deliberate Front-Foot No Balls
- Law 41.9 Time Wasting by Fielding Side
- Law 41.10 Time Wasting by Batsmen
- Law 41.13 Bowler Running on Protected Area after Delivering the Ball
- Law 41.12 Fielder Damaging the Pitch
- Law 41.14 Batsman Damaging the Pitch
- Law 41.17 Batsman Stealing a Run
- Law 42 Players Conduct

**Were the Captains Informed?** Yes / No

If required, please give further details of report and incidents, on the reverse of this sheet.

**Umpire's Name:** ..... **Colleague:** .....

**Signed:** ..... **Date:** .....



**APPENDIX L: SNCL UMPIRE'S GROUND ASSESSMENT FORM**

Ground Assessment & Team Conduct Report Card			
<b>Fixture Details</b>			
	<b>Home Team</b>	<b>Vs</b>	<b>Away Team</b>
<b>Fixture:</b>			
<b>Date of Fixture:</b>		<b>Weather:</b>	
<b>Division:</b>		<b>Type of Match:</b>	
<b>Umpire's Name:</b>		<b>Colleague's Name:</b>	
<b>Appointment:</b>		<b>Appointment:</b>	
<b>Scorer (Home):</b>		<b>Scorer (Away):</b>	
<b>Team Sheet (Home):</b>		<b>Team Sheet (Away):</b>	
<b>Details of Team Conduct</b>			
	<b>Home Team</b>		<b>Away Team</b>
Acceptance of Decisions		Acceptance of Decisions	
Respect for Umpire		Respect for Umpire	
Respect for Opposition		Respect for Opposition	
Sportsmanship		Sportsmanship	
General Behaviour		General Behaviour	
Language		Language	
Captains Co-operation		Captains Co-operation	
Overall Mark (Out of 10)		Overall Mark (Out of 10)	
<b>Discipline Issues</b>			
<b>Where there any issues of Discipline and / or Misconduct:</b>			
<b>Will you be Sending a Written Report:</b>			
<b>Brief Details:</b>			
<b>Ground Report (Pitch &amp; Square)</b>			
<b>State:</b>		<b>Pace:</b>	
<b>Consistency:</b>		<b>Bounce:</b>	
<b>Turn:</b>		<b>Moisture:</b>	
<b>Surface (initial)</b>		<b>Deterioration:</b>	
<b>Grass Covering:</b>		<b>Length:</b>	
<b>Pitch Markings:</b>		<b>Stumps &amp; Bails:</b>	
<b>Pitch Overall Mark:</b>		<b>Square Condition:</b>	

Ground Report (Outfield)			
Surface:		Grass Length:	
Boundary Marked:		Boundary Markers:	
Sightscreens:		Sawdust:	
Covers:		Type & Condition:	
Ground Report (Facilities)			
Changing Rooms:		Condition:	
Showers for Teams?		Toilets (M&F):	
Umpires Changing:		Condition:	
Umpires Shower:			
Scoreboard:		Scorebox:	
Clubhouse:			
Match Times / Details			
First Innings:		Overs Bowled:	
Start Time:		Finish Time:	
Time (Hrs)	2.50	Over Rate:	0.00
Weather Interruption:		No. of Overs Reduced:	
Second Innings:		Overs Bowled:	
Start Time:		Finish Time:	
Time (Hrs)	2.50	Over Rate:	0.00
Weather Interruption:		No. of Overs Reduced:	
Other Items			
Teas Provided:		Standard:	
Fees Paid at Tea:		If not, when?	
Was the Match Report Sheet Completed for End of Match:			
If Not - How Long After the Match was the Sheet Completed:			
Other Comments			

## **APPENDIX M: DEFINITION OF A 'FREE-HIT'**

The following relates to Rules 4.6.4:

### **No Ball**

The penalty for the no ball shall be one run. In addition, the delivery following a no ball shall be a free hit for whichever batsman is facing it.

### **Free Hit**

For any free hit, the striker can be dismissed only under the circumstances that apply for a no ball (Law 21.15) even if the delivery for the free hit is called a wide ball.

Field changes are not permitted for free hit deliveries unless there is a change of striker save that in all circumstances, any fielder within 15 yards of the striker may retreat to a position on the same line no more than 15 yards from the striker.

The Umpires will signal a free hit by (after the normal No Ball signal) extending one arm straight upwards and moving it in a circular motion.

If the delivery for the free hit is not a legitimate delivery (any kind of no ball or a wide ball), then the next delivery will become a free hit for whichever batsman is facing it.

## APPENDIX N: CALCULATION OF OVER RATES AND PENALTY DEDUCTIONS

**Worked Example:** League Match

Commencement 1.30pm;

40 overs maximum permitted, 2 hours 30 minutes maximum time allowance. Innings to conclude at 4.00pm (2 hours, 30 minutes) - Any overs not completed (due to the fault of the bowling side) will be bowled, deficiency to be reported to the Captain and the League, the equivalent points deducted. Say 3 overs short, team to lose 3 points. Tea taken at 4.15pm

Re-Commence following tea, say 4.45pm;

Revised match conclusion to be 4.45pm plus 2 hours 30 minutes (i.e. 7.15pm). Any overs not completed at the scheduled finish time for the second innings, will continue to be bowled in order to achieve a result, deficiency to be reported to the Captain and the League and equivalent points deducted.

If in this case, the team bowling second completes the overs in time, but loses, the team batting first would be awarded a win (20 points) less 3 points, total 17 points.

In order to achieve a result of the match, all overs must be bowled otherwise there will be issues in achieving a win or lose, and matches would be draws, which was agreed was not a route we ought to take. Cricket should be played to win or lose.

Full tables of timings to be provided in the rule book for Clubs and Umpires to be fully aware of timings and deductions.

If in the case that the delays were caused by lost balls, the batting side or injury, the Umpires shall stop the clock to ensure fairness to the fielding team. The Umpires will be required to report stoppages and causes of delays accordingly.

**APPENDIX O: UMPIRE ASSESSMENT FORM & GUIDANCE NOTES**

Umpire Assessment Form			
<b>Match Details</b>			
	<b>Home Team</b>	<b>Vs</b>	<b>Away Team</b>
<b>Fixture:</b>			
<b>Date of Fixture:</b>		<b>Division:</b>	Premier / Division 1
		<b>Type of Match:</b>	League / Cup
<b>Captain's Name:</b>		<b>Your Club:</b>	
<b>Umpire Assessment (Marks out of 10)</b>			
	<b>Umpire 1</b>		<b>Umpire 2</b>
<b>Umpire's Name:</b>		<b>Umpire's Name:</b>	
<b>Appointment:</b>	League / Club	<b>Appointment:</b>	League / Club
Match Control		Match Control	
Confidence		Confidence	
Consistency		Consistency	
Communication		Communication	
Concentration		Concentration	
Decision Making		Decision Making	
For any score of 4 or below, please provide reasons for the mark in the box below.			
<b>Other Comments</b>			
<b>Guidance Notes</b>			
<b>(10-9) Very Good</b> - Significantly Above the Expected Standard; <b>(8-7) Good</b> - Meets the Expected Standard;			
<b>(6-5) Acceptable</b> - Most Areas Met but Room for Improvement;			
<b>(4-2) Poor</b> - Some Areas Met, Generally Below Expected Standard; <b>(1) Very Poor</b> - Significantly Below the Expected Standard;			
Match Control - Appropriate Levels of Intervention; Knowledge and Application of Laws of Cricket; Positioning;			
Confidence - Maintained Composure Throughout; Confidence with Ground, Weather and Light, Rain Delays etc...;			
Consistency - Consistent Decision Making Throughout;			
Communication - Clear Audible Calls for Players; Interaction with Captains and Players; Clear Signals; Works with Colleague;			
Concentration - Aware and Alert at all Times;			
Decisions - See Guidance Notes;			
Captain's should be objective when completing the Umpire Assessment Report. The Report is designed so that the overall performance of the Umpire can be assessed and not just the decision making.			
Please e-mail completed form to <a href="mailto:assessments@snclcricket.co.uk">assessments@snclcricket.co.uk</a> within 3 days of the match (i.e. Tuesday for a Saturday fixture).			

## Umpire Assessment Guidance Notes

When completing the Captains Report please take into account the notes shown below:

Captains should be objective when completing the Report. It is designed so that the overall performance of the umpire can be assessed and **not just the decision making**.

The information supplied helps with the development of umpires and improvement of their performance. Where umpires gain low marks in any category then this information may be used to provide further guidance or training.

At the end of the season the marks are used to 'grade' umpires locally, and will be supplied to the ECB to assist in the further development of umpires and to make regional and national appointments (for those Umpires who accept these appointments).

### Match Control – Did the Umpire?

- Ensure that the timings for the match and intervals were followed?
- Ensure covers were used, if required?
- Involve his colleague when it was necessary to speak to either captain?
- Interpret ground, weather and lights issues effectively?
- Deal effectively with any potential conflict situation?
- Use common sense when dealing with players?
- Allow the match to be played but have an appropriate level of intervention?
- Apply the Laws of the Game, Spirit of Cricket and Disciplinary Sanctions effectively?

### Confidence - Did the Umpire?

- Have a confident and positive manner throughout the match?
- Consider appeals in a calm and confident manner?

### Consistency - Did the Umpire?

- Make decisions consistently throughout the match?
- Have a consistent interpretation of wide balls, leg byes and no balls?

### Communication – Did the Umpire?

- Communicate effectively with the captains, players, with his colleague throughout the match?
- Communicate effectively with the scorers and wait for response?
- Conduct a pre-match discussion prior to the toss?
- Obtain team sheets and match balls?
- With colleague, raise any issues related to the match with the captains including 'Spirit of Cricket'?
- Have a polite and friendly attitude throughout the match?

### Concentration - Was the Umpire?

- Fully alert and aware at all times throughout the match?

### Decision Making – Did the Umpire?

- So far as you are aware, apply the Laws of Cricket correctly when making decisions?
- Consult his colleague where necessary?
- Get into position, at either end, in order to make correct decisions for No balls, Run outs or Short runs?
- If utilised, manage a runner for an injured batsman effectively?

# SOUTH NORTHANTS CRICKET LEAGUE

## CONSTITUTION OF DIVISIONS 2026 SEASON

### PREMIER DIVISION (9)

Banbury Lions CC  
Evenley CC  
Syresham CC  
Sibford CC  
Kings Sutton CC  
Finmere CC

Great Northampton CC  
Castlethorpe CC  
Maids Moreton CC

### DIVISION ONE (8)

Wicken CC  
Printers CC  
Hanslope CC  
Bodicote CC  
Evenley 'A' CC  
Chipping Warden CC

Great Northampton 'A' CC  
Shenley Church End CC

### DIVISION TWO (8)

Wardington CC

Banbury Lions 'A' CC  
Preston Bissett CC  
Crown CC  
Syresham 'A' CC

Middleton Cheney 'B' CC  
Heyford CC  
Bodicote 'A' CC

### Withdrawals:

Byfield CC (*League Change*)  
Woodford Halse CC (*League Change*)  
Wroxton CC (*League Change*)  
Brackley CC (*League Change*)  
Thornborough CC (*League Change*)

### New Entries:

Bodicote 'A' CC  
Shenley Church End CC  
Middleton Cheney 'B' CC  
Heyford CC

# SOUTH NORTHANTS CRICKET LEAGUE

## Fixtures 2026

Saturday 2<sup>nd</sup> May 2026

Bank Holiday Weekend (1)

### Premier Division

Kings Sutton	V	Bye
Finmere	V	Sibford
Evenley	V	Great Northampton
Maids Moreton	V	Banbury Lions
Syresham	V	Castlethorpe

### Division 1

Great Northampton 'A'	V	Evenley 'A'
Shenley Church End	V	Wicken
Bodicote	V	Chipping Warden
Printers	V	Hanslope

### Division 2

Banbury Lions 'A'	V	Syresham 'A'
Wardington	V	Middleton Cheney
Preston Bissett	V	Heyford
Crown	V	Bodicote 'A'

### **Fixture Requests:**

*Castlethorpe (No Home Fixture)*

**Premier Division**

Maids Moreton	V	Kings Sutton
Sibford	V	Evenley
Bye	V	Great Northampton
Finmere	V	Castlethorpe
Banbury Lions	V	Syresham

**Division 1**

Evenley 'A'	V	Chipping Warden
Great Northampton 'A'	V	Bodicote
Shenley Church End	V	Printers
Hanslope	V	Wicken

**Division 2**

Syresham 'A'	V	Wardington
Preston Bissett	V	Middleton Cheney
Bodicote 'A'	V	Banbury Lions 'A'
Heyford	V	Crown

**Fixture Requests:**

*Castlethorpe (No Home Fixture)*

*Printers (Away)*

*Wicken (Away)*

**Premier Division**

Kings Sutton	V	Banbury Lions
Castlethorpe	V	Sibford
Evenley	V	Bye
Great Northampton	V	Maids Moreton
Finmere	V	Syresham

**Division 1**

Wicken	V	Evenley 'A'
Printers	V	Great Northampton 'A'
Shenley Church End	V	Chipping Warden
Bodicote	V	Hanslope

**Division 2**

Syresham 'A'	V	Bodicote 'A'
Wardington	V	Preston Bissett
Middleton Cheney	V	Heyford
Banbury Lions 'A'	V	Crown

***Fixture Requests:***

**Saturday 23<sup>rd</sup> May 2026****Bank Holiday Weekend (4)****Premier Division**

Evenley	V	Kings Sutton
Syresham	V	Sibford
Bye	V	Maids Moreton
Great Northampton	V	Finmere
Banbury Lions	V	Castlethorpe

**Division 1**

Bodicote	V	Evenley 'A'
Shenley Church End	V	Great Northampton 'A'
Printers	V	Wicken
Hanslope	V	Chipping Warden

**Division 2**

Heyford	V	Syresham 'A'
Crown	V	Wardington
Preston Bissett	V	Banbury Lions 'A'
Middleton Cheney	V	Bodicote 'A'

***Fixture Requests:***

**Premier Division**

Kings Sutton	V	Great Northampton
Sibford	V	Banbury Lions
Finmere	V	Bye
Maids Moreton	V	Syresham
Castlethorpe	V	Evenley

**Division 1**

Evenley 'A'	V	Printers
Great Northampton 'A'	V	Chipping Warden
Wicken	V	Bodicote
Hanslope	V	Shenley Church End

**Division 2**

Syresham 'A'	V	Crown
Banbury Lions 'A'	V	Middleton Cheney
Bodicote 'A'	V	Preston Bissett

*Heyford Vs Wardington (20.06.26)*

**Fixture Requests:**

*Printers (Away)*

*Shenley Church End (Away)*

*Wardington (No Fixture)*

**Premier Division**

Sibford	V	Kings Sutton
Bye	V	Castlethorpe
Great Northampton	V	Syresham
Evenley	V	Maids Moreton
Finmere	V	Banbury Lions

**Division 1**

Hanslope	V	Great Northampton 'A'
Bodicote	V	Printers
Chipping Warden	V	Wicken

*Shenley Church End V Evenley 'A' (27.06.26)*

**Division 2**

Wardington	V	Bodicote 'A'
Syresham 'A'	V	Middleton Cheney
Crown	V	Preston Bissett
Banbury Lions 'A'	V	Heyford

**Fixture Requests:**

*Printers (Away)*

*Shenley Church End (Away)*

*Wicken (Away)*

**Premier Division**

Kings Sutton	V	Finmere
Maids Moreton	V	Sibford
Syresham	V	Bye
Castlethorpe	V	Great Northampton
Banbury Lions	V	Evenley

**Division 1**

Evenley 'A'	V	Hanslope
Great Northampton 'A'	V	Wicken
Shenley Church End	V	Bodicote
Printers	V	Chipping Warden

**Division 2**

Preston Bissett	V	Syresham 'A'
Wardington	V	Banbury Lions 'A'
Bodicote 'A'	V	Heyford
Middleton Cheney	V	Crown

**Fixture Requests:**

*Syresham (No Home Fixture)*

*Hanslope (No Home Fixture)*

**Premier Division**

Syresham	V	Kings Sutton
Bye	V	Sibford
Great Northampton	V	Banbury Lions
Castlethorpe	V	Maids Moreton
Finmere	V	Evenley

**Division 1 - (League Cup - Round 1)**

**(20 Overs as per Cup Rules)**

<b>Match 1 -</b> Chipping Warden	V	Shenley Church End
<b>Match 2 -</b> Hanslope	V	Bodicote
<b>Match 3 -</b> Evenley 'A'	V	Printers
<b>Match 4 -</b> Wicken	V	Great Northampton

**Division 2**

Bodicote 'A'	V	Crown
Heyford	V	Wardington

Remaining Teams - Bye Week

**Fixture Requests:**

*Sibford (No Home Fixture)*

*Printers (Away)*

*Shenley Church End (Away)*

**Premier Division**

Kings Sutton	V	Castlethorpe
Sibford	V	Great Northampton
Banbury Lions	V	Bye
Maids Moreton	V	Finmere
Evenley	V	Syresham

**Division 1**

Shenley Church End	V	Evenley 'A'
Chipping Warden	V	Bodicote

Remaining Teams - Bye Week

**Division 2 - (League Cup - Round 1)**

**(20 Overs as per Cup Rules)**

<b>Match 1 -</b> Crown	V	Banbury Lions
<b>Match 2 -</b> Wardington	V	Preston Bissett
<b>Match 3 -</b> Middleton Cheney	V	Syresham 'A'
<b>Match 4 -</b> Bodicote 'A'	V	Heyford

***Fixture Requests:***

*Wicken (Away)*

**Premier Division**

Bye	V	Kings Sutton
Sibford	V	Finmere
Great Northampton	V	Evenley
Banbury Lions	V	Maids Moreton
Castlethorpe	V	Syresham

**Division 1**

Evenley 'A'	V	Great Northampton 'A'
Wicken	V	Shenley Church End
Hanslope	V	Printers

*Chipping Warden V Bodicote (27.06.26)*

**Division 2**

Syresham 'A'	V	Banbury Lions 'A'
Middleton Cheney	V	Wardington
Heyford	V	Preston Bissett

*Bodicote 'A' V Crown (20.06.26)*

**Fixture Requests:**

*Bodicote (No Fixture)*

*Kings Sutton (No Fixture)*

*Bodicote 'A' (No Fixture)*

*Printers (Away)*

*Shenley Church End (Away)*

**Premier Division**

Kings Sutton	V	Maids Moreton
Evenley	V	Sibford
Great Northampton	V	Bye
Castlethorpe	V	Finmere
Syresham	V	Banbury Lions

**Division 1**

Chipping Warden	V	Evenley 'A'
Bodicote	V	Great Northampton 'A'
Wicken *	V	Hanslope
Printers	V	Shenley Church End

*\* Could be Reversed - Ground Clash*

**Division 2**

Wardington	V	Syresham 'A'
Middleton Cheney	V	Preston Bissett
Banbury Lions 'A'	V	Bodicote 'A'
Crown	V	Heyford

**Fixture Requests:**

*Wicken (Away)*

**Premier Division**

Banbury Lions	V	Kings Sutton
Sibford	V	Castlethorpe
Bye	V	Evenley
Maids Moreton	V	Great Northampton
Syresham	V	Finmere

**Division 1**

Evenley 'A'	V	Wicken
Great Northampton 'A'	V	Printers
Chipping Warden	V	Shenley Church End
Hanslope	V	Bodicote

**Division 2**

Bodicote 'A'	V	Syresham 'A'
Preston Bissett	V	Wardington
Heyford	V	Middleton Cheney
Crown	V	Banbury Lions 'A'

**Fixture Requests:**

*Printers (Away)*

*Shenley Church End (Away)*

**Premier Division**

Kings Sutton	V	Evenley
Sibford	V	Syresham
Maids Moreton	V	Bye
Finmere	V	Great Northampton
Castlethorpe	V	Banbury Lions

**Division 1**

Evenley 'A'	V	Bodicote
Great Northampton 'A'	V	Shenley Church End
Chipping Warden	V	Hanslope
Wicken	V	Printers

**Division 2**

Syresham 'A'	V	Heyford
Wardington	V	Crown
Banbury Lions 'A'	V	Preston Bissett
Bodicote 'A'	V	Middleton Cheney

**Fixture Requests:**

*Printers (Away)*

*Shenley Church End (Away)*

**Premier Division**

Great Northampton	V	Kings Sutton
Banbury Lions	V	Sibford
Bye	V	Finmere
Syresham	V	Maids Moreton
Evenley	V	Castlethorpe

**Division 1**

Printers	V	Evenley 'A'
Chipping Warden	V	Great Northampton 'A'
Bodicote	V	Wicken
Shenley Church End	V	Hanslope

**Division 2**

Crown	V	Syresham 'A'
Middleton Cheney	V	Banbury Lions 'A'
Wardington	V	Heyford
Preston Bissett	V	Bodicote 'A'

***Fixture Requests:***

*Wicken (Away)*

**Premier Division**

Kings Sutton	V	Sibford
Castlethorpe	V	Bye
Syresham	V	Great Northampton
Maids Moreton	V	Evenley
Banbury Lions	V	Finmere

**Division 1**

Evenley 'A'	V	Shenley Church End
Great Northampton 'A'	V	Hanslope
Printers	V	Bodicote
Wicken	V	Chipping Warden

**Division 2**

Middleton Cheney	V	Syresham 'A'
Heyford	V	Banbury Lions 'A'
Bodicote 'A'	V	Wardington
Preston Bissett	V	Crown

***Fixture Requests:***

**Premier Division**

Finmere	V	Kings Sutton
Sibford	V	Maids Moreton
Bye	V	Syresham
Great Northampton	V	Castlethorpe
Evenley	V	Banbury Lions

**Division 1**

Hanslope	V	Evenley 'A'
Wicken *	V	Great Northampton 'A'
Bodicote	V	Shenley Church End
Chipping Warden	V	Printers

*\* Ground Clash - Home Primacy or Subject to Cup Results Play 22.08.26 or 29.08.26*

**Division 2**

Syresham 'A'	V	Preston Bissett
Heyford	V	Bodicote 'A'
Banbury Lions 'A'	V	Wardington
Crown	V	Middleton Cheney

**Fixture Requests:**

*Printers (Away)*

*Shenley Church End (Away)*

*Wicken (Away)*

**Premier Division**

Kings Sutton	V	Syresham
Sibford	V	Bye
Banbury Lions	V	Great Northampton
Maids Moreton	V	Castlethorpe
Evenley	V	Finmere

**Division 1 - (League Cup Semi - Finals)**

**(20 Overs as per Cup Rules)**

<b>Semi Final 1 -</b> Winner Match 2	V	Winner Match 3
<b>Semi Final 2 -</b> Winner Match 1	V	Winner Match 4

**Division 2 - (League Cup Semi - Finals)**

**(20 Overs as per Cup Rules)**

<b>Semi Final 1 -</b> Winner Match 2	V	Winner Match 4
<b>Semi Final 2 -</b> Winner Match 3	V	Winner Match 1

***Fixture Requests:***

*Wicken (Away)*

**Saturday 29<sup>th</sup> August 2026****Bank Holiday Weekend (18)****Premier Division**

Castlethorpe	V	Kings Sutton
Great Northampton	V	Sibford
Bye	V	Banbury Lions
Finmere	V	Maids Moreton
Syresham	V	Evenley

**Division 1 - (League Cup Final)****(20 Overs as per Cup Rules)**

Winner Semi-Final 1	V	Winner Semi-Final 2
---------------------	---	---------------------

**Division 2 - (League Cup Final)****(20 Overs as per Cup Rules)**

Winner Semi-Final 2	V	Winner Semi-Final 1
---------------------	---	---------------------

***Fixture Requests:***

# SOUTH NORTHANTS CRICKET LEAGUE

## Premier Division Knockout Cup

### 1<sup>st</sup> Round

To be played on Thursday 2<sup>nd</sup> July 2026 (or Thursday 9<sup>th</sup> July 2026 if wet):

A	Sibford	V	Syresham
B	Great Northampton	V	Bye
C	Finmere	V	Kings Sutton
D	Banbury Lions	V	Castlethorpe

### Semi-Finals

To be played on Thursday 16<sup>th</sup> July 2026 (or Thursday 23<sup>rd</sup> July 2026 if wet):

1	B	V	C
2	D	V	A

### Final

To be played on Sunday 26<sup>th</sup> July 2026 (12.30pm) (Venue to be Arranged):

2	V	1
---	---	---

## Division One Knockout Cup

### 1<sup>st</sup> Round

To be played on Saturday 20<sup>th</sup> June 2026:

A	Chipping Warden	V	Shenley Church End
B	Hanslope	V	Bodicote
C	Evenley 'A'	V	Printers
D	Wicken	V	Great Northampton

### Semi-Finals

To be played on Saturday 22<sup>nd</sup> August 2026:

1	B	V	C
2	A	V	D

### Final

To be played on Saturday 29<sup>th</sup> August 2026 (12.30pm) (Venue to be Arranged):

1	V	2
---	---	---

# SOUTH NORTHANTS CRICKET LEAGUE

## Division Two Knockout Cup

### 1<sup>st</sup> Round

To be played on Saturday 27<sup>th</sup> June 2026:

A	Crown	V	Banbury Lions
B	Wardington	V	Preston Bissett
C	Middleton Cheney	V	Syresham 'A'
D	Bodicote 'A'	V	Heyford

### Semi-Finals

To be played on Saturday 22<sup>nd</sup> August 2026:

1	B	V	D
2	C	V	A

### Final

To be played on Saturday 29<sup>th</sup> August 2026 (4.00pm) (Venue to be Arranged):

2	V	1
---	---	---

# SOUTH NORTHANTS CRICKET LEAGUE

## Wardington Cup

### 1<sup>st</sup> Round

To be played on Tuesday 16<sup>th</sup> June 2026 (or Tuesday 23<sup>rd</sup> June 2026 if wet):

A	Kings Sutton	V	Sibford
B	Shenley Church End	V	Banbury Lions
C	Chipping Warden	V	Great Northampton
D	Bye	V	Syresham

### Semi-Finals

To be played on Tuesday 7<sup>th</sup> July 2026 (or Tuesday 14<sup>th</sup> July 2026 if wet):

1	C	V	Syresham
2	A	V	B

### Final

To be played on Sunday 26<sup>th</sup> July 2026 (4.00pm) (Venue to be Arranged):

1	V	2
---	---	---

